

# SKOFLO

High Turn Down Valve  
Model SF5000HTD  
Operations and Maintenance Manual

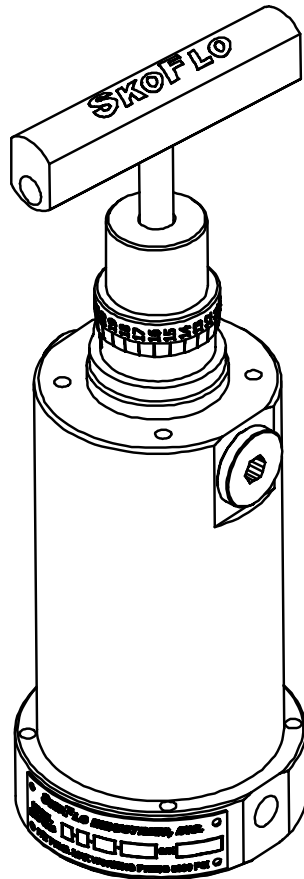

[WWW.SKOFLO.COM](http://WWW.SKOFLO.COM)

P.O. BOX 1728 Woodinville, WA 98072 USA  
425.485.7816 FAX 425.368-1696

**SKOFLO** INDUSTRIES INC.

---

## PRINCIPLE OF OPERATION:

SkoFlo high turn down valves maintain constant flow rate by governing pressure drop across an internal restrictor with the use of a spring balanced piston mating with a throttling seat shown in the illustration below. The internal restrictor is located between the interface of the gate and pad shown below and is made up of a series of cascading flow restrictors that are varied as the stem is adjusted to change the flow rate set point.

At full scale flow rate set point a minimum of 250psi is required to achieve the set point accuracy. With a 250psi drop across the valve half of the pressure drop is experienced across the restrictor and the remaining half across the mating pin and seat shown in the illustration below. For pressures greater than 250psi across the valve, the pressure drop across the restrictor remains the same with the balance taken up by the mating pin and seat. Below 25% full scale set point less than 100psi is required to achieve set point accuracy.

Stem movement also increases the pressure drop governed across the restrictor at the same time the restriction passage sizes are increased so the highest flow rate set point has the largest passages and the highest pressure drop across the restrictor and the lowest flow set point has the lowest pressure drop set point and smallest passages. When the stem is fully open, the valve will pass up to .04 inch diameter and at the lowest set point will pass .003 inch particles for the .5 to 250gpd range and .005 inch particles for the 1 to 500 and the 15 to 1500gpd range.

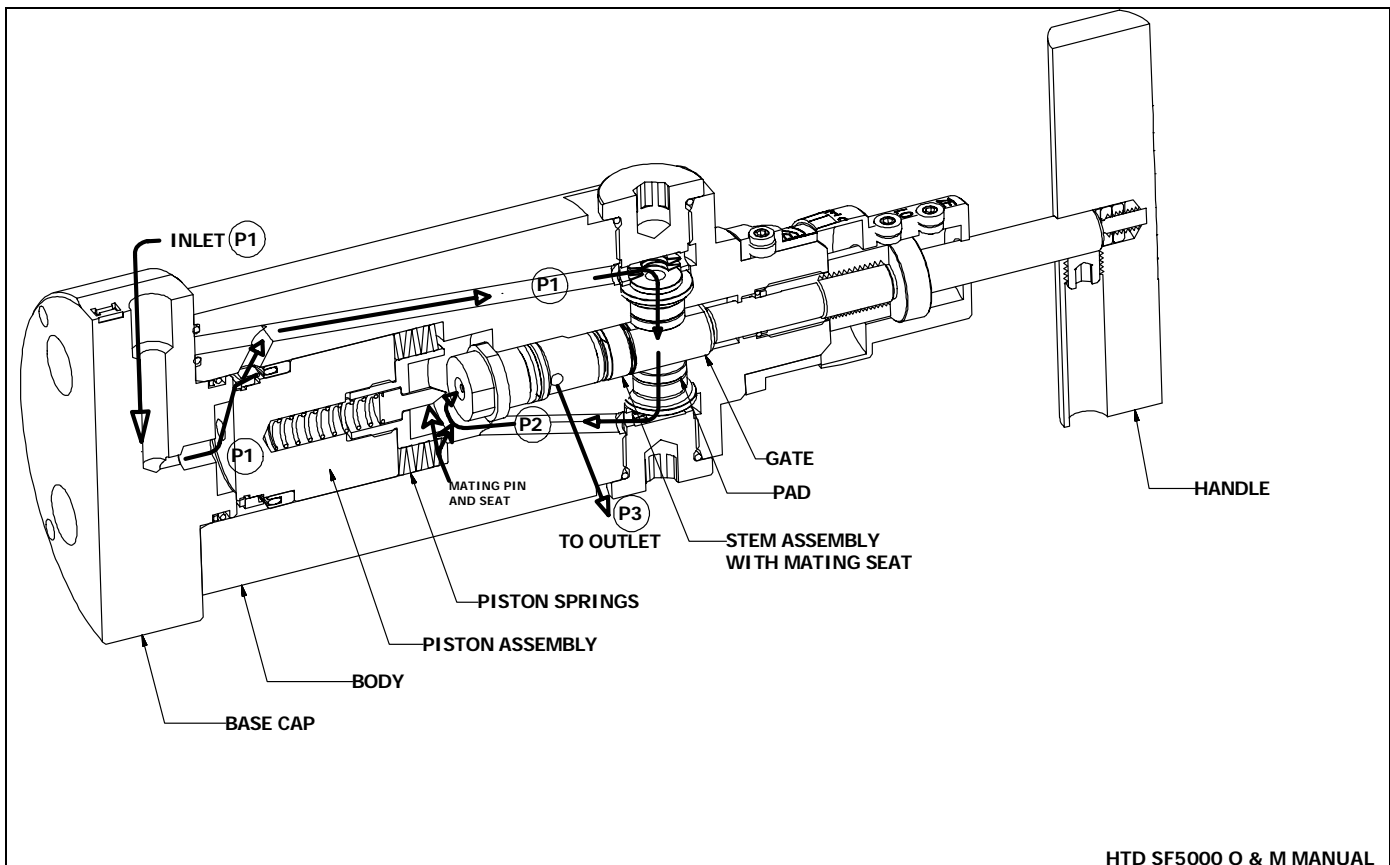

Figure 1

## ADJUSTMENT AND CALIBRATION:

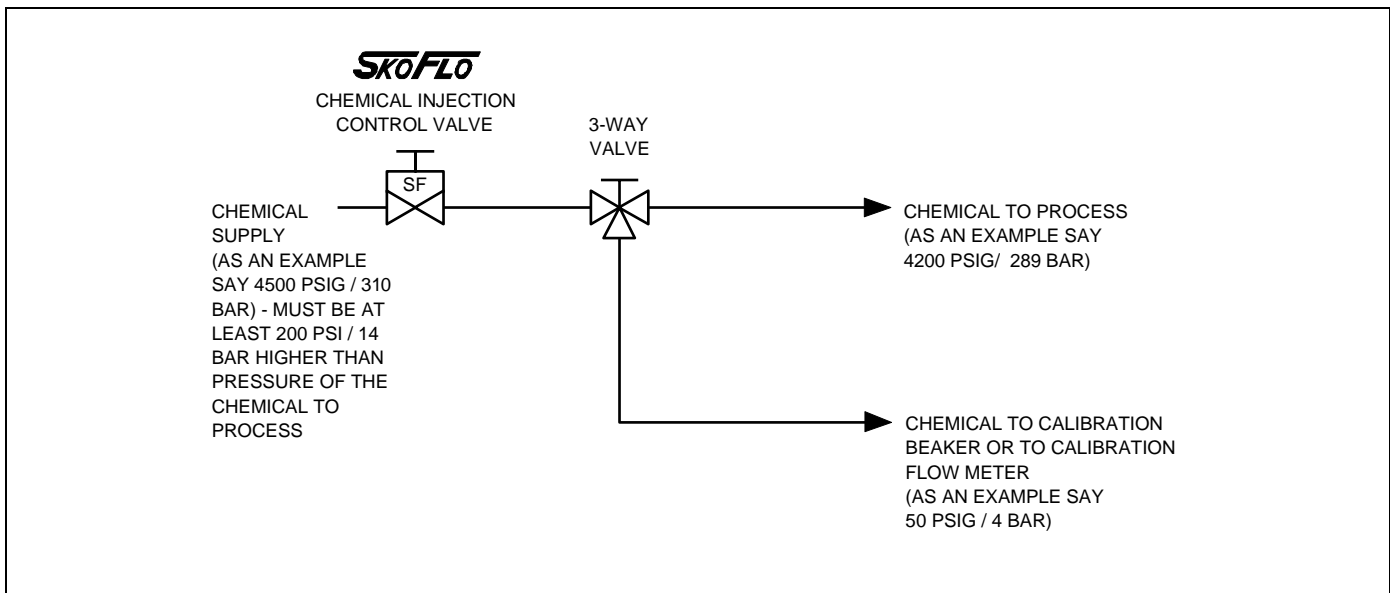

Figure 2

The SkoFlo Valve is a pressure independent flow control valve. Once the valve is set at a desired flow rate, that flow rate is maintained even though the pressure conditions upstream and/or downstream of the valve may change considerably. The tolerance that flow rate is held constant is as follows; for flow rate set point above 25% of full scale the flow rate will not change more than 3% of reading per 1000psi change in pressure drop across the valve with the flow rate diminishing with increasing pressure drop across the valve. Below 25% of full scale and above the minimum rated flow, the rate will change 6% of reading per 1000psi change in pressure drop.

The standard Multi-Point SkoFlo valve is set by manually adjusting the rate adjustment handle. When the desired flow rate is set, the valve remains at that fixed flow rate until the rate adjustment handle is turned to a new setting. For best results the four turn handle must be opened one full turn counter clockwise before reaching the final set point to eliminate backlash caused by mating threads in the stem mechanism.

The flow rate can be set using a flow meter in the line to the process. However, a flow meter in this line must be capable of withstanding the process pressure. This normally limits the availability of this type flow meter.

The most common method of calibrating the SkoFlo Valve is with a 3-way valve and a line to a calibration beaker or to a low pressure flow meter. Once the flow rate is set, the 3-way valve is switched to direct the chemical to the process. In larger systems flow meters can be used along with a calibration line and 3-way valves located upstream of the SkoFlo valves.

Since the SkoFlo Valve flows at the set rate nearly independent of the pressure differential across the SkoFlo Valve, the flow rate to the process is the same as the flow rate set using the beaker or flow meter. Overall monitoring of the flows is done by taking inventory of the usage from the supply tank.

In the above example, the SkoFlo Valve is set with a differential pressure of 4450psi / 306 bar across the valve using the flow meter at 50psi. The flow rate set will increase  $3\% \times 4000/1000 = 12\%$  for flow rates above 25% full scale and 24% for flow rates below 25% full scale when the chemical is routed to process and the SkoFlo Valve has a differential pressure of 300 psi / 21 bar.

# THE VALVE

## Valve Performance Curve

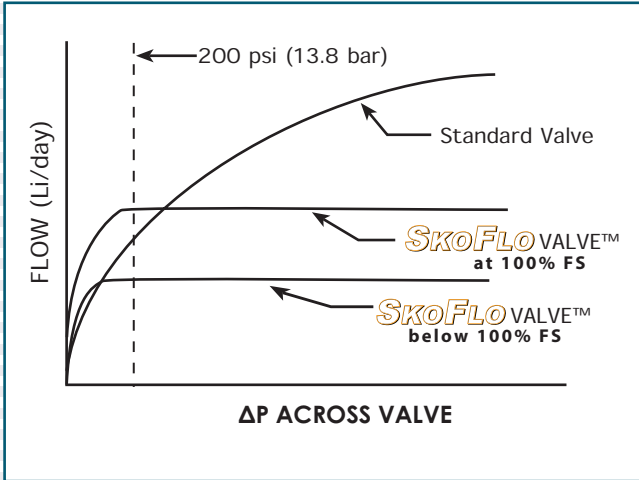

Notes: (Assuming Cv remains constant for both valves)

- Standard Valve:** flow rate varies as the square root of the differential pressure across the standard control valve.
- SkoFlo Valve:** flow rate remains constant once the minimum differential pressure is reached across the SkoFlo valve.

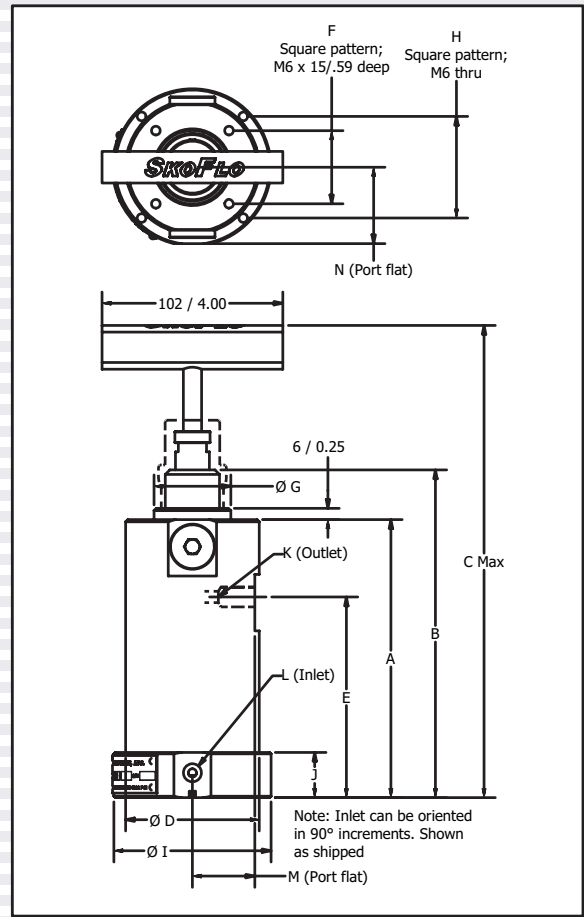

MODEL	DIMENSIONS (mm/in)													
	"A"	"B"	"C"	"D"	"E"	"F"	"G"	"H"	"I"	"J"	"K"	"L"	"M"	"N"
HTD-10000	157 / 6.18	184 / 7.25	269 / 10.60	88 / 3.48	113 / 4.44	41 / 1.62	31 / 1.20	57 / 2.25	88 / 3.48	13 / 0.50	3/8 AEMP	3/8 AEMP	42 / 1.64	43 / 1.69
HTD-5000	156 / 6.15	184 / 7.25	269 / 10.60	75 / 2.9	113 / 4.44	41 / 1.62	31 / 1.20	57 / 2.25	88 / 3.48	13 / 0.50	1/4 NPT	1/4 NPT	35 / 1.68	43 / 1.69

Consult factory for current outline drawings

# THE SYSTEM

## SkoFlo Multi-Point System Utilizing a Positive Displacement Pump

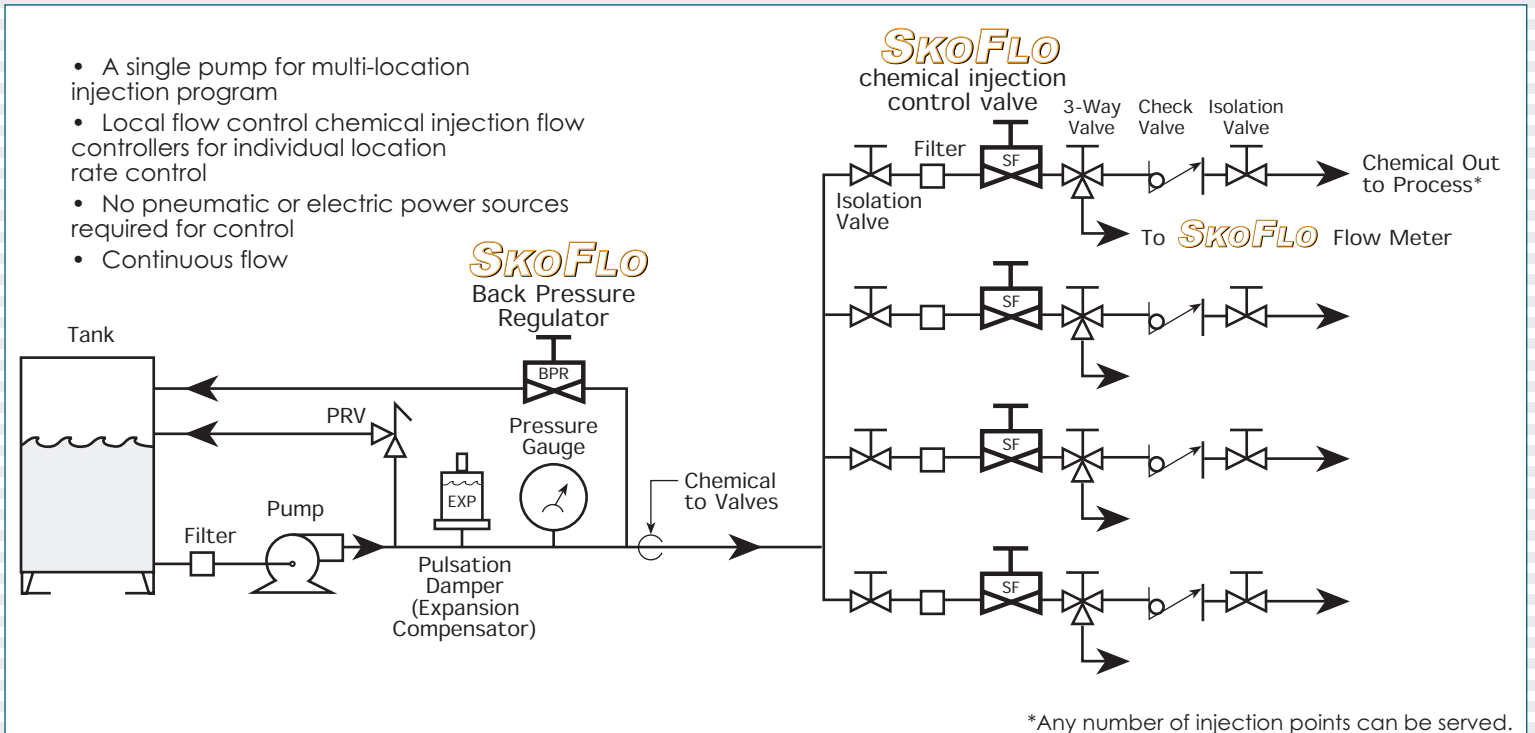

\*Any number of injection points can be served.

Notes: For systems **not** using a positive displacement pump the pulsation damper and back pressure regulator are not required.

## INSTALLATION PROCEDURES:

- 1) Install valve so that the flow is in the proper direction. The "INLET" and "OUTLET" connections are ¼" NPT female pipe threads.
- 2) Filter size as follows to protect the smallest opening at the lowest flow rate set point:  
  
Range .5 to 300 US gallons per day = 40 micron to protect 85 micron openings  
  
Range 1 to 500 US gallons per day = 60 micron to protect 125 micron openings  
  
Range 15 to 1500 US gallons per day = 80 micron to protect 160 micron openings  
  
Note: the preferred filter location is immediately before the valve.
- 3) A pulsation dampener is recommended to be installed on the inlet header supplying the SkoFlo valves for improved longevity set point consistency. A bladder type pulsation dampener is preferred over a piston type. Reactive dampeners that use baffles will do little to dampen the SkoFlo over the full flow rate range of the SkoFlo valve.
- 4) The valve can be mounted in any orientation. The base plate can be rotated 90 degree increments.
- 5) If panel mounting SkoFlo valves remove the handle with a M4 Allen wrench to loosen the M8 cup point screw securing the handle to the stem. When installing the handle take care to line up the M8 cup point screws on the flat of the stem.
- 6) If automatic shut off valves are to be installed in series with the SkoFlo valve, the outlet of the SkoFlo valve is the preferred location. The SkoFlo valve is designed to withstand pressure shocks across the valve due to the rapid opening of automatic shut off valves on the outlet of the SkoFlo.
- 7) The SkoFlo Valve is not a positive shut off device so a valve on the inlet or outlet will be required to meet shut off specifications. The preferred location of the shut off valve is on the outlet of the SkoFlo valves to minimize damage to internal parts during start up before supply lines to the SkoFlo become fluid packed.
- 8) A check valve is recommended to be installed immediately down stream of the valve (within 6 inches) to prevent damage to the piston cup seal and to prevent well fluids entering the SkoFlo valve. The 6 inch maximum is recommended to eliminate stored pressure build up during start up due to entrained gas. All seals are retained for reverse flow condition. With reverse flow pressure exceeding 2,000psi differential (138bar) damage may occur to the piston cup seal. Check valve cracking pressure is recommended to be under 10psi to enhance longevity of check valve seats.
- 9) The dial on the stem has been factory set for a 25% glycol in water solution at 80deg F (27deg C) where zero is the lowest flow on the offered range of the valve. The dial setting for the maximum flow rate range will vary valve to valve and is listed on the valve calibration sheet. There are no conversion for the dial settings and the respective flow rates for chemicals. The dial is intended to be used as a **reference** set point for flow measurements taken in the field –not an inference of flow from the factory calibration using 25% glycol/water mix. The ring portion of the dial with 0 150 can be rotated to improve visibility. The lock screw is generally not use because the valve will hold it's position during shipment with extreme vibration.

## **START UP PROCEDURES:**

### **1) CAUTION**

Open the outlet isolation valve, then open the supply isolation valve on the inlet to the SkoFlo valve **slowly** if it is anticipated that there is entrapped air in the lines.

- 2) Turn the pressure adjustment handle until you are at the desired flow rate. Always start at a flow rate above the desired flow and decrease to the desired setting, usually  $\frac{1}{4}$  turn (turn handle clockwise to decrease flow rate). For the most consistent set point results turn one full turn clockwise to reach the set point.

Note: Approximately  $3\frac{1}{2}$  turns will go from full scale to the lowest set point or 86 divisions on the stem for a 25% glycol water solution.

- 3) When increasing the flow rate set point over the maximum flow rate range the handle will free turn when a stem stop inside the valve is reached. With continued counter-clockwise rotation approximately  $\frac{1}{4}$  turn the handle will reach a stop and increase in torque will be noticed.

### **CAUTION**

Further rotation in the counter clockwise rotation at torques greater than 5 foot-lbs (0.7 Kg-m) may cause the pull rod in the stem to be damaged.

Note: Should the pull rod be damaged or removed the stem will not leak

## OPERATION NOTES AND WARNINGS:

- 1) The SkoFlo Flow Rate Regulator has hard seats and is not designed to provide complete "bubble-tight" shut off. If tight shutoff is required, separate isolation valves should be used for shutting off the flow. **Over-tightening the handle will not further reduce flow.** If flow rate does not decrease when turning the handle clock wise, see "Trouble Shooting Improper Valve Performance".
- 2) Do not flow backwards through the SkoFlo valve. Internal seals are designed for one direction only and could possibly become damaged if reverse pressure exceeds 2,000psi (138bar).
- 3) Install relief valve and/or burst plate upstream of the SkoFlo Rate Control Regulator as required.
- 4) If stem is to be replaced to access stem seal, Locktite and sufficient torque must be applied to ensure stem nut does not back off –see Fig. 3 Page 11 for replacing stem nut and stem seal
- 5) Check chemical compatibility of seal material against chemicals to be used in the field. Seal materials offered are:

Viton equivalent denoted HTD-5000-**V**

Kalrez equivalent denoted HTD-5000-**K**

EPDM equivalent denoted HTD-5000-**E**

HNBR equivalent denoted HTD-5000-**H**

VITON B equivalent denoted HTD-5000-**VB**

## MAINTENANCE NOTES:

- 1) When replacing valve seals, it is recommended that the new seals be lubricated with Parker Super Lube or equivalent. Install the backup ring on low pressure side of o-ring and make sure the backup ring is lined up at the joint. See Fig. 4 Page 13
- 2) Fastener and Torque Summary:

<b>PARTS JOINED</b>	<b>FASTENER DESCRIPTION</b>	<b>THREAD COMPOUND</b>	<b>TOOL REQUIRED</b>	<b>TORQUE REQUIRED</b>
Base Cap to Body	M8-30 Socket Head Cap Screw	Never Seize	M 6 Allen Wrench	10-15 ft-lbs (1.4-2 Kg-m)
Gate Pad Cap to Body	Machined Components	Never Seize	M8 Allen Wrench	30 ft-lbs (2.8 -4 Kg-m)
Stem Nut to Body	Machined Components	Loctite #271 and Primer	16 mm Crows Foot Wrench	30 ft-lbs (2.8 -4 Kg-m)
Handle to Stem	M8 Cup Point	Never Seize	M6 Allen Wrench	10-15 ft-lbs (1.4-2 Kg-m)
Flow Dial Ring To Stem	M4 Cup Point	None	2 mm Allen Wrench	Finger tight
Flow Dial Thimble To Stem "Zero"	M4 Cup Point	None	2 mm Allen Wrench	Finger tight
Flow Dial Thimble To Stem "Lock"	M4 Cup Point	None	2 mm Allen Wrench	Finger tight (Not Recommended for use)
Pin Holder to Piston	Machined Components	None	22.5 mm Open End Wrench	5 ft-lbs (0.7 Kg-m)
Pull Rod to Stem	#8 Jam Nuts	None	9 mm Open End Wrench x 2	2-3 ft lbs (0.3 -0.4 Kg-m)

Table 1

NOTE: Loctite #271 requires heat (such as a propane torch) to disassemble.



## TROUBLESHOOTING IMPROPER VALVE PERFORMANCE:

<u>SYMPTOM</u>	<u>CAUSE</u>	<u>REMEDY</u>
1. No flow	Upstream filter is plugged.	Clean or replace filter element.
	SkoFlo regulator is plugged.	Turn stem counter clock wise until flow increases to near full scale to open up the internal restrictor. passages. Take apart and clean if this does not work. Correct the cause of plugging such as a leaking filter.
	Supply valve is shutoff.	Open valve <b>slowly</b> .
	Discharge line is shut off.	Open valve.
2. Fluctuations in flow rate with changing pressure drop across valve	Piston springs are not installed properly	Install springs in accordance with valve assembly drawing Fig. 3 Page 11
	Seat or pin worn or damaged	Replace seat holder or pin
	Supply pressure not adequate	Flow Controller requires a minimum of 250 psi (17.2 bar) differential across the valve for full rated flow
3. Flow rate set point drifts over time	Stem has not been rotated one full turn clock wise to reach set point	Turn stem counter clock wise one rotation then clockwise one rotation to set point
	Internal restrictor is plugging	Turn stem counter clock wise until flow increases to near full scale to open up internal restrictor. passages. Take apart and clean if this does not work. Correct the cause of plugging such as a leaking filter or filter is not sized as recommended for the lowest flow rate settings outlined in Installation Procedures above
4. Flow rate not being controlled by handle	Handle has come loose.	Torque M8 cup point screw against flat on stem to torque setting below

Table 2

## FOR ADDITIONAL INFORMATION:

Please call the factory in Woodinville, Washington USA at phone number (425)485-7816 if you have any questions.

E-Mail: [butchs@skoflo.com](mailto:butchs@skoflo.com)

## RECOMMENDED SPARE PARTS:

The numbers listed below are recommended for each 10 units in service

<u>QTY</u>	<u>PART NUMBER</u>	<u>DESCRIPTION</u>
1	22677	Seat Holder Assembly
2	22637	Pad Assembly
1	See Table 4 on Page 12 for correct material selection	Seal Kit

Table 3

## STORAGE:

- 1) When storing SkoFlo valves prior to first use, it is recommended that the valves be stored Indoors. If stored outdoors, apply a light coating of protectant to the exterior of the valve. The shipping plugs in the inlet, outlet, drain/pressure ports and vent should remain in place.
- 2) When storing SkoFlo valves after being in use, flush the valve with chemicals that will not oxidize or thicken when exposed to air.

SEE PARTS LIST FOR PART NUMBERS

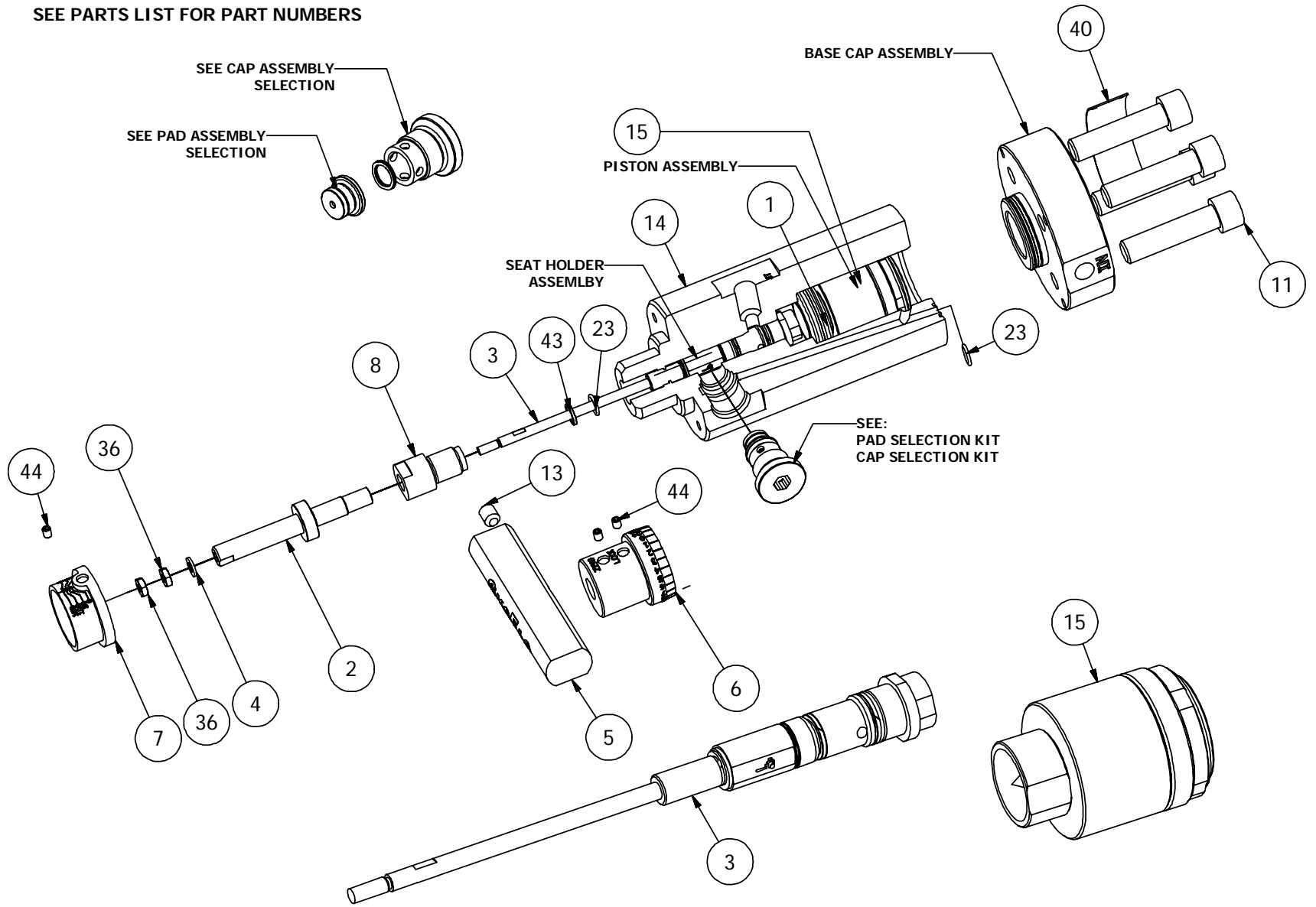

**SF 5000 HTD EXPLODED VIEW**

## PARTS LIST:

### SF 5000 HTD EXPLODED VIEW PARTS LIST

ITEM	QTY	PART NUMBER	DESCRIPTION
1	5	71001962	BELLEVILLE SPRING
2	1	21263	STEM, HTD VALVE
3	1	22677	SEAT HOLDER ASSY, HTD SF5000
4	1	21265	SEAT HOLDER LIFT ROD WASHER
5	1	21266	HANDLE TOP, HTD
6	1	21267	VERNIER DIAL, HTD
7	1	21268	VERNIER SLEEVE, HTD
8	1	21277	STEM BUSHING
11	4	71002093	M8-1.25 SHCS
13	1	71002937	M8 X 10 CUP POINT SET SCREW
14	1	21262	BODY, HTDV
15	1	22621	PISTON ASSEMBLY
23	2	71001743	O-RING
36	2	71002974	#8 Hex Machine Screw Nut
40	1	21620	NAMEPLATE HTD VALVE
43	1	21811	SOLID BACK UP RING FOR HTD VALVE
44	3	71002861	M4 x 6 Cup Point hexagon socket set screws
PAD ASSY	2	22637	HTD, SF 5000 PAD ASSY, KALREZ
PAD ASSY	2	22638	HTD, SF 5000 PAD ASSY, VITON
PAD ASSY	2	22639	HTD, SF 5000 PAD ASSY, EPDM
PAD ASSY	2	22640	HTD, SF 5000 PAD ASSY, VITON B
PAD ASSY	2	22641	HTD, SF 5000 PAD ASSY, HNBR
CAP ASSY	2	22642	HTD, SF 5000 CAP ASSY, KALREZ
CAP ASSY	2	22643	HTD, SF 5000 CAP ASSY, VITON
CAP ASSY	2	22644	HTD, SF 5000 CAP ASSY, EPDM
CAP ASSY	2	22645	HTD, SF 5000 CAP ASSY, VITON B
CAP ASSY	2	22646	HTD, SF 5000 CAP ASSY, HNBR
SEAL KIT	1	22421	SEAL KIT, HTD SF5000 VITON
SEAL KIT	1	22422	SEAL KIT, HTD SF5000 EPDM
SEAL KIT	1	22423	SEAL KIT, HTD SF5000 KALREZ
SEAL KIT	1	22618	SEAL KIT, HTD SF5000 VITON B
SEAL KIT	1	22619	SEAL KIT, HTD SF5000 HNBR

Table 4

## REPLACING:

### BASE CAP (or rotating)

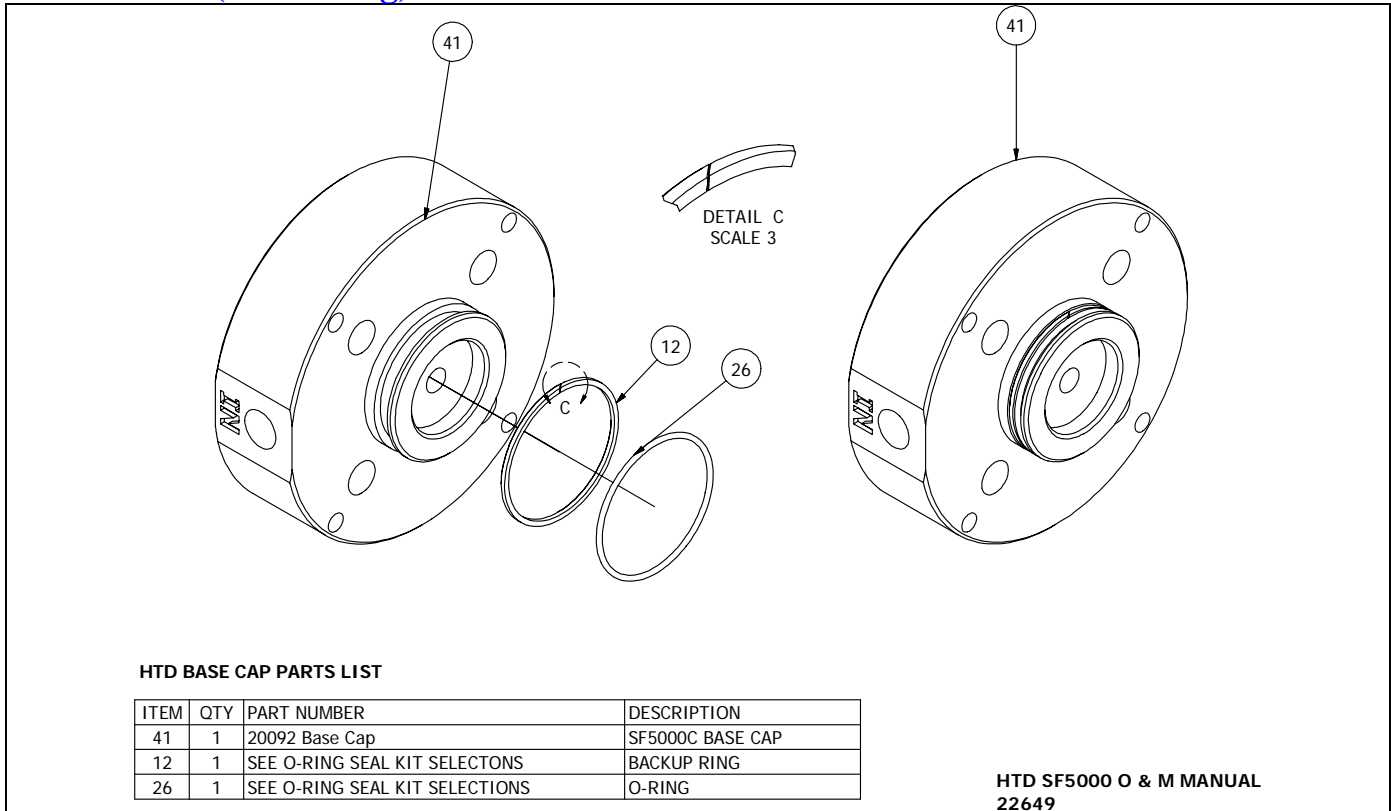

Figure 4

### PISTON ASSEMBLY

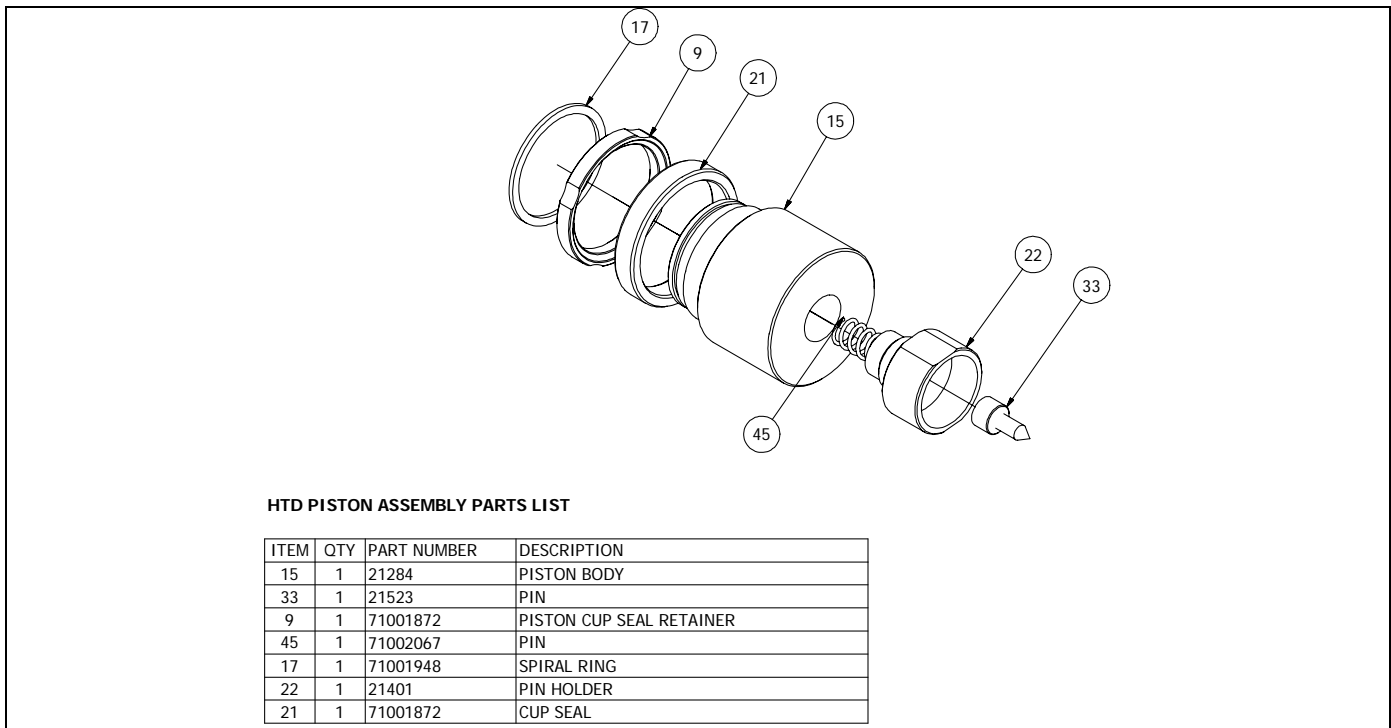

Figure 5

# SKOFLO INDUSTRIES, INC.

www.skoflo.com

PO BOX 1728, 14241 NE 200th , Bldg A, Suite B  
Woodinville Wa, 98072 USA  
425.485.7816 FAX 425.368.1696

Our focus is on you our customer and for ISO 9001:2000 compliance we have prepared and request that you take the time to complete this **customer satisfaction survey**.

Company:	
Contact:	
Email:	
Phone:	

Please rate following categories	Highly Dissatisfied			N/A		Highly Satisfied	
	<input type="checkbox"/>	<input type="checkbox"/>	<input type="checkbox"/>	<input type="checkbox"/>	<input type="checkbox"/>	<input type="checkbox"/>	<input type="checkbox"/>
1. Product Quality	<input type="checkbox"/>	<input type="checkbox"/>	<input type="checkbox"/>	<input type="checkbox"/>	<input type="checkbox"/>	<input type="checkbox"/>	<input type="checkbox"/>
2. Product Features	<input type="checkbox"/>	<input type="checkbox"/>	<input type="checkbox"/>	<input type="checkbox"/>	<input type="checkbox"/>	<input type="checkbox"/>	<input type="checkbox"/>
3. Reliability	<input type="checkbox"/>	<input type="checkbox"/>	<input type="checkbox"/>	<input type="checkbox"/>	<input type="checkbox"/>	<input type="checkbox"/>	<input type="checkbox"/>
4. After sale support	<input type="checkbox"/>	<input type="checkbox"/>	<input type="checkbox"/>	<input type="checkbox"/>	<input type="checkbox"/>	<input type="checkbox"/>	<input type="checkbox"/>
5. Implementation	<input type="checkbox"/>	<input type="checkbox"/>	<input type="checkbox"/>	<input type="checkbox"/>	<input type="checkbox"/>	<input type="checkbox"/>	<input type="checkbox"/>
6. Delivery	<input type="checkbox"/>	<input type="checkbox"/>	<input type="checkbox"/>	<input type="checkbox"/>	<input type="checkbox"/>	<input type="checkbox"/>	<input type="checkbox"/>

Score from 1 (Low ) to 7 (High)	(Low)			N/A		(High)	
	1	2	3	4	5	6	7
Recommend SkoFlo to friend or colleague.	<input type="checkbox"/>	<input type="checkbox"/>	<input type="checkbox"/>	<input type="checkbox"/>	<input type="checkbox"/>	<input type="checkbox"/>	<input type="checkbox"/>
Likely to Purchase Products from SkoFlo	<input type="checkbox"/>	<input type="checkbox"/>	<input type="checkbox"/>	<input type="checkbox"/>	<input type="checkbox"/>	<input type="checkbox"/>	<input type="checkbox"/>
Overall quality of relationship with SkoFlo	<input type="checkbox"/>	<input type="checkbox"/>	<input type="checkbox"/>	<input type="checkbox"/>	<input type="checkbox"/>	<input type="checkbox"/>	<input type="checkbox"/>
Overall level of satisfaction with SkoFlo	<input type="checkbox"/>	<input type="checkbox"/>	<input type="checkbox"/>	<input type="checkbox"/>	<input type="checkbox"/>	<input type="checkbox"/>	<input type="checkbox"/>
Overall level of satisfaction with respect to Product Valve	<input type="checkbox"/>	<input type="checkbox"/>	<input type="checkbox"/>	<input type="checkbox"/>	<input type="checkbox"/>	<input type="checkbox"/>	<input type="checkbox"/>
Overall level of satisfaction with respect to product engineering	<input type="checkbox"/>	<input type="checkbox"/>	<input type="checkbox"/>	<input type="checkbox"/>	<input type="checkbox"/>	<input type="checkbox"/>	<input type="checkbox"/>
Level of confidence of SkoFlo abilities to provide compliant product	<input type="checkbox"/>	<input type="checkbox"/>	<input type="checkbox"/>	<input type="checkbox"/>	<input type="checkbox"/>	<input type="checkbox"/>	<input type="checkbox"/>
Comments:							