

UTILIZING PRESSURE INDEPENDENT TECHNOLOGY IN TOPSIDE DISTRIBUTED CHEMICAL INJECTION SYSTEMS

ABSTRACT

This paper discusses how SkoFlo's pressure independent CIMVs address system instabilities and ensure accurate and reliable chemical injection in a Topside Distributed System. A recent study¹ indicates chemical operational expenditure to be the second highest with an increase in 2017 to \$10.5B. A few contributing factors for this increased operational expenses are highlighted. A comparative analysis is established on pressure independent and pressure dependent methods of flow control.

INTRODUCTION

A study from FB industries¹ projected chemicals to be the second highest operational expense spending approximately \$9.5 billion dollars in 2016. Chemical spend is projected to rise to \$10.5B in 2017.

Topside and subsea chemical injection must be optimum and reliable to overcome substantial operational expenditures. Utilizing pressure dependent methods of flow control (e.g. needle valves) will cause system instabilities, erratic, and unreliable chemical injection.

PRIMARY CAUSES FOR INSTABILITIES IN A DISTRIBUTED CHEMICAL INJECTION SYSTEM

- Change in well pressure due to
 - Gas breakout in fluid column
 - Reservoir pressure
 - Gas lift conditions
 - Shut In
- Change in supply pressure due to
 - Pump delivery curve
 - Trunk line and branched line losses
 - Additional wells coming online / going offline
- Changes in differential pressure (DP) across a pressure dependent flow control valve.
- System imbalance due to pressure dependent flow control valve interactions (see figure 1 for a distributed chemical injection system schematic)
- Filming and debris – Pressure dependent valves cannot respond properly to filming and debris.

OTHER CAUSES OF INSTABILITIES

Figure 2 shows DP vs flow comparisons at different % stem opening for a pressure dependent valve. Pressure dependent flow control valves vary in flow rate when upstream or downstream pressure changes. The valve must be adjusted either manually or with an actuated stem to compensate for pressure fluctuations².

- For a pressure dependent valve, a given change in DP causes a change in flow across the valve and/or branch. This can be mathematically explained as follows in equation 1:

$$Q = C_v \sqrt{\frac{DP}{SG}} \quad (1)$$

*Q = Flow in Gallons per minute (GPM),
C_v = Valve flow coefficient,
DP = Differential pressure between inlet and outlet of valve(psi).
SG = Specific Gravity*

$$Q_2 = Q_1 * \sqrt{\frac{DP_2}{DP_1}} \quad (2)$$

From equation 2 and figure 2, flow changes 55% from 10 to 20 bar pressure differential at 60% stem opening and 10% from 60 to 70 bar pressure differential at 60% stem opening.

- Rangeability is the ratio of maximum controllable flow to minimum controllable flow. Greater the change in DP across the stem, less predictable the flow for a pressure dependent valve. Rangeability³ is reduced due to actual operation by the varying valve pressure drop. This will adversely affect the chemical dosage rate for a pressure dependent valve which significantly increases operational expense.

Furthermore, when chemical injection systems have multiple branched lines, pressure dependent flow control valves, or actuated needle valves have a cause and effect relationship with each other. For every pressure imbalance, a pressure dependent flow control valve must be adjusted in response resulting in erratic delivery of chemicals. All flow control valves on the branch must then also readjust set flow rate resulting in overdosing and underdosing. Manually controlled needle valves will require personnel to constantly adjust set flow rate.

To overcome the limitations of pressure dependent flow control valves, operators typically set target flow rates higher than what is required to eliminate the risk of underdosing.

SkoFlo pressure independent CIMVs on the other hand respond to pressure changes and system instabilities with no oversight.

2. https://www.flowcontrol.com/documents/FCI_Applications_Frequently%20Asked%20Questions_SEPT%202010.pdf
3. http://chemical.eng.usm.my/notes/SUHAI/notes/CONTROL%20VALVE_Theory.pdf

SKOFLO PRESSURE INDEPENDENT CIMVS

SkoFlo's pressure independent technology (figure 3) uses mechanically activated spring balance piston to respond to any system pressure fluctuation, debris, or filming. No set point adjustments or tuning of the control loops are required to maintain constant flow. The mechanical spring balanced piston in each branched loop responds instantaneously to maintain system stability and accurate delivery.

Figure 4 illustrates DP vs Flow for a pressure independent SkoFlo CIMV. Once a minimum differential pressure across the CIMV is achieved, the delivered flow will remain within the narrow accuracy bandwidth regardless of system instabilities. A graph showing how pressure independent SkoFlo CIMVs respond to system pressure fluctuations compared to pressure dependent CIMVs is illustrated in figure 5.

With very little oversight over the life of the field, the operational cost savings can be enormous (see appendix 1 for operational cost savings using Pressure Independent CIMVs). Additionally, once the target flow rate is set, SkoFlo CIMVs do not require adjustment for any system pressure fluctuation due to the robust mechanical nature of the CIMV.

CONCLUSION

Pressure dependent valves are prone to erratic flow delivery. A small percent increase in chemical usage due to erratic delivery results in much larger operational cost. In today's environment where cost savings are of paramount importance, it is critical to evaluate operational costs when making capex decisions. Maintaining a stable chemical injection system is critical for cost savings and operators are urged to evaluate and adopt the most reliable and accurate pressure independent CIMV to address system instabilities.

REFERENCES

1. *PC180 Case Study.pdf*

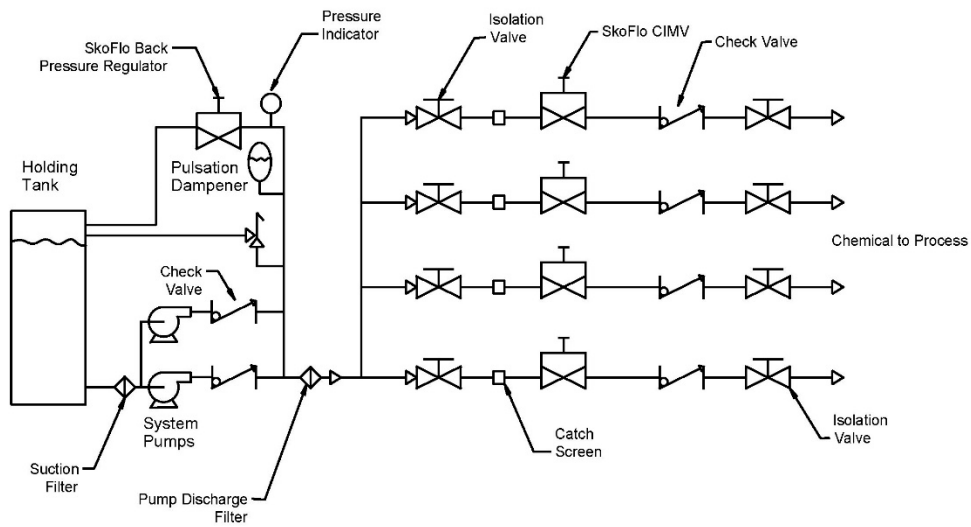

Figure 1. Distributed Chemical Injection System Schematic

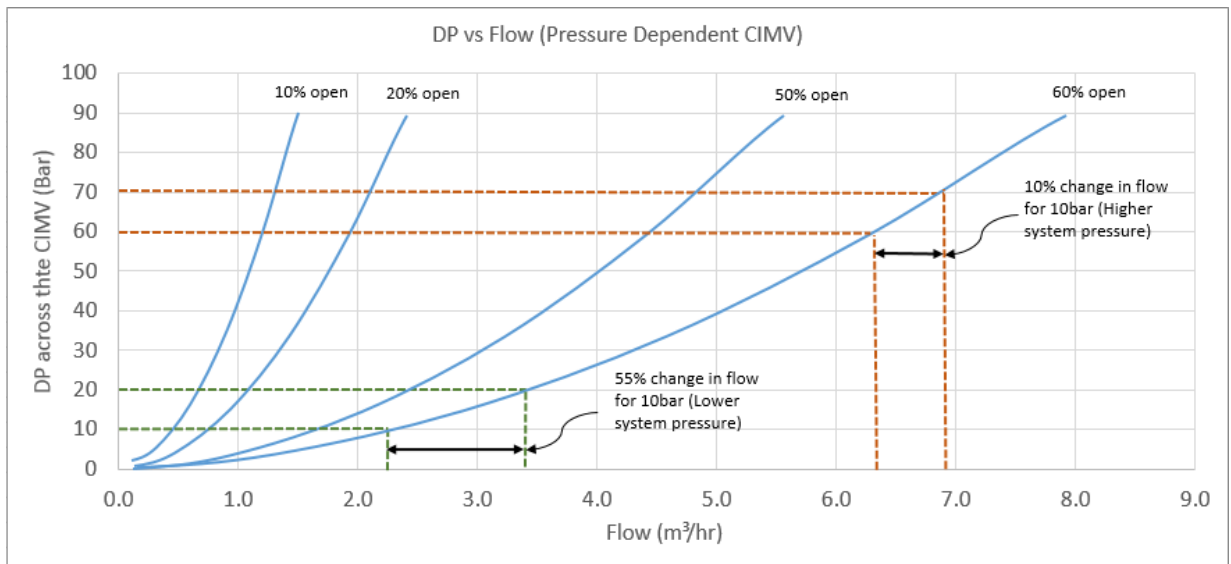

Figure 2. DP vs Flow (Pressure Dependent Valve)

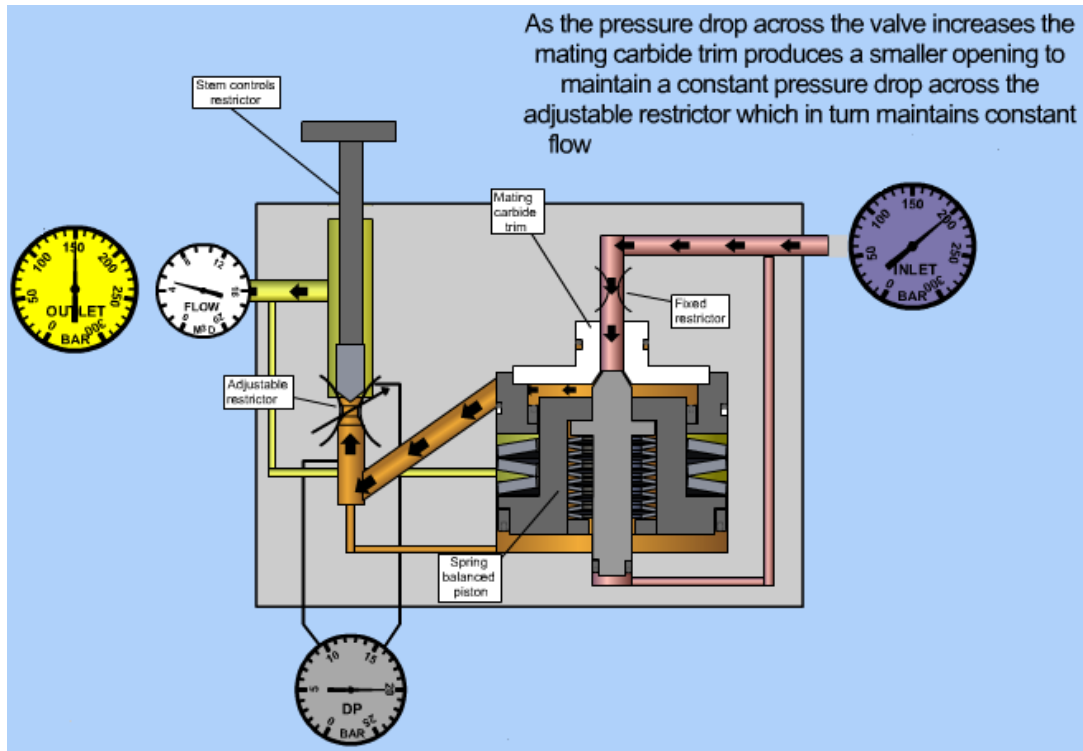

Figure 3. SkoFlo's Pressure Independent CIMV

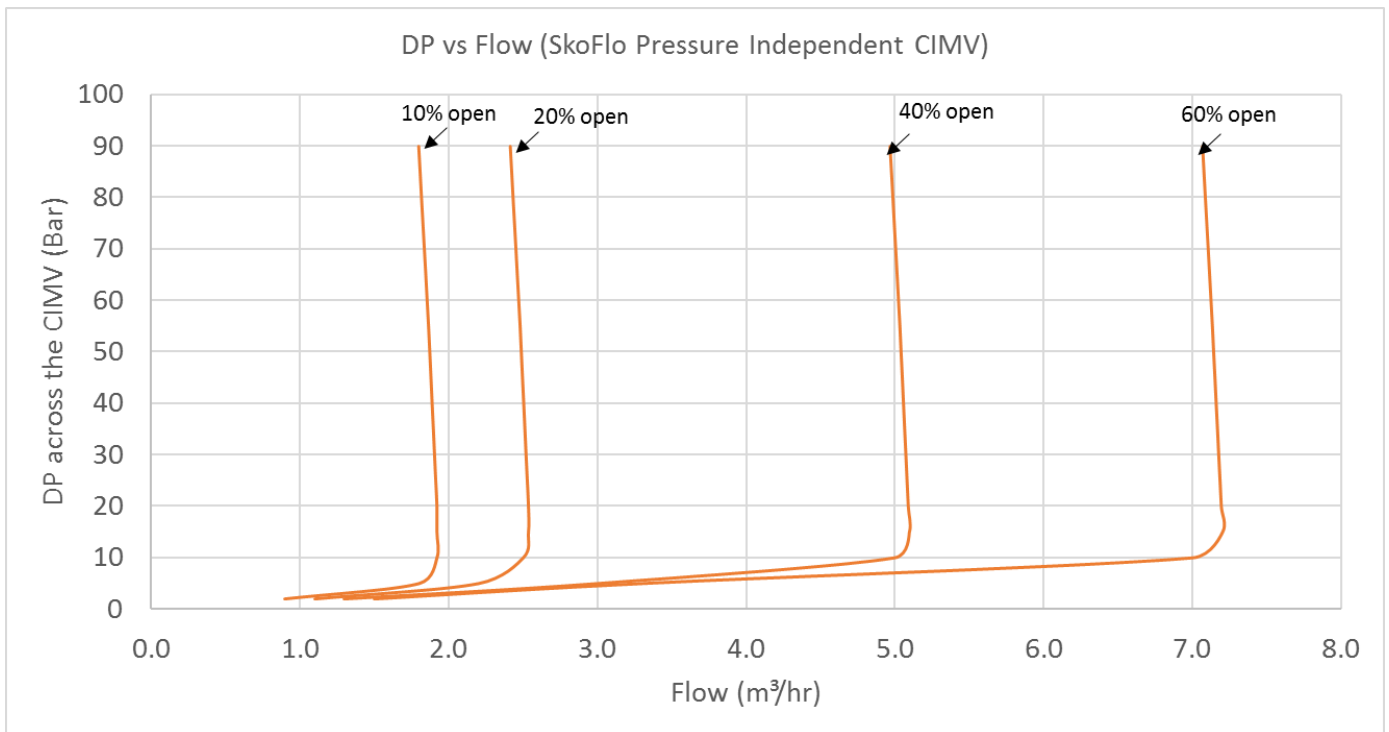

Figure 4. DP vs Flow for a SkoFlo Pressure Independent CIMV

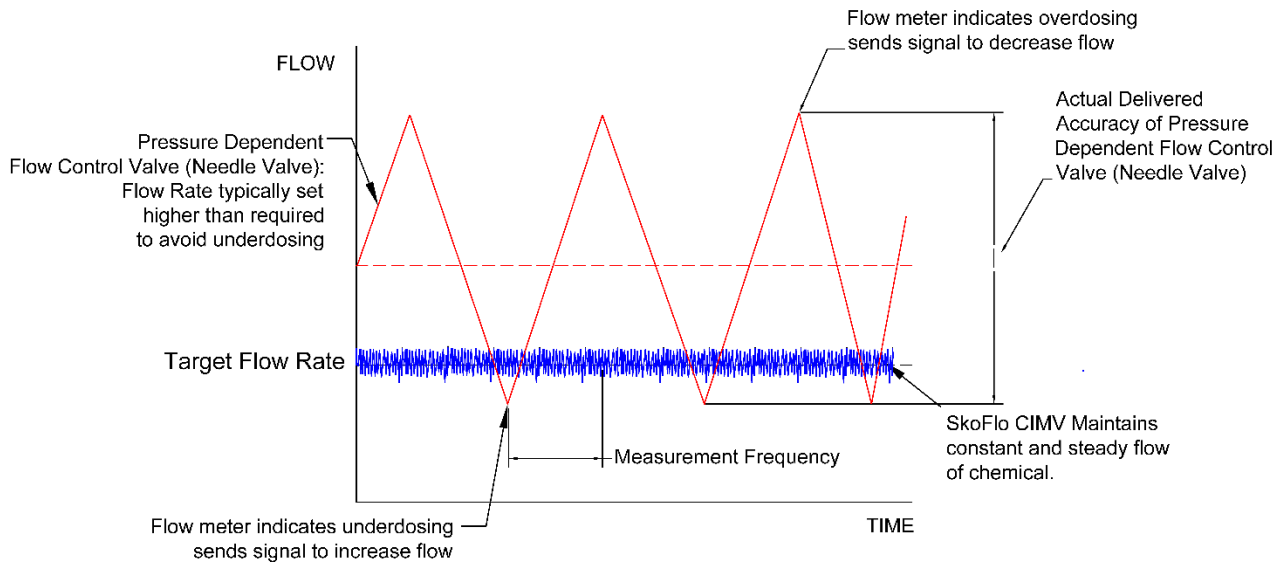

Figure 5. Response Time Curve (SkoFlo Pressure Independent CIMV vs Pressure Dependent Valve)

APPENDIX 1: COST ANALYSIS (SAMPLE PROJECT)

SkoFlo’s pressure Independent Chemical Injection Metering Valves (CIMVs) deliver stable, reliable, continuous, and accurate flow of chemicals. This translates to significant savings in annual OPEX by minimizing chemical waste due to overdosing.

**Pressure Dependent Flow
Control Valve chemical
wastage due to system
instability**

Qty CIMVs	Chemical	Flow Rate (GPM)	Total Gallons/Year	\$/Gallon	Annual Chemical Cost*	5% Over dose	10% Over dose
6	Wax Inhibitor	0.051	161,481	\$ 20.00	\$ 3,229,624	\$ 161,481	\$ 322,962
12	Corrosion Inhibitor	0.004	24,521	\$ 18.00	\$ 441,373	\$ 22,069	\$ 44,137
12	80 % MEG**	22.015	41,655,902	\$ 12.00	\$ 499,870,829	\$ 24,993,541	\$ 49,987,083
3	Methanol	11.0075	17,356,626	\$ 1.25	\$ 21,695,783	\$ 1,084,789	\$ 2,169,578
				Totals	\$ 525,237,608	\$ 26,261,880.39	\$ 52,523,760.78
*based on estimated market prices in 2016							
**assume 70% MEG recovery with no cost for refining							