

REVISION HISTORY							
ECN #	REV	DESCRIPTION	DATE	DRAWN	ENG1	ENG2	OTHER
	A	INITIAL RELEASE	10/23/18	JM	NA	SS	
2633	B	UPDATE PN: AC WAS 240A, DC WAS 24DC, ADD TORQUES	12/17/18	JM	NA	JCD	

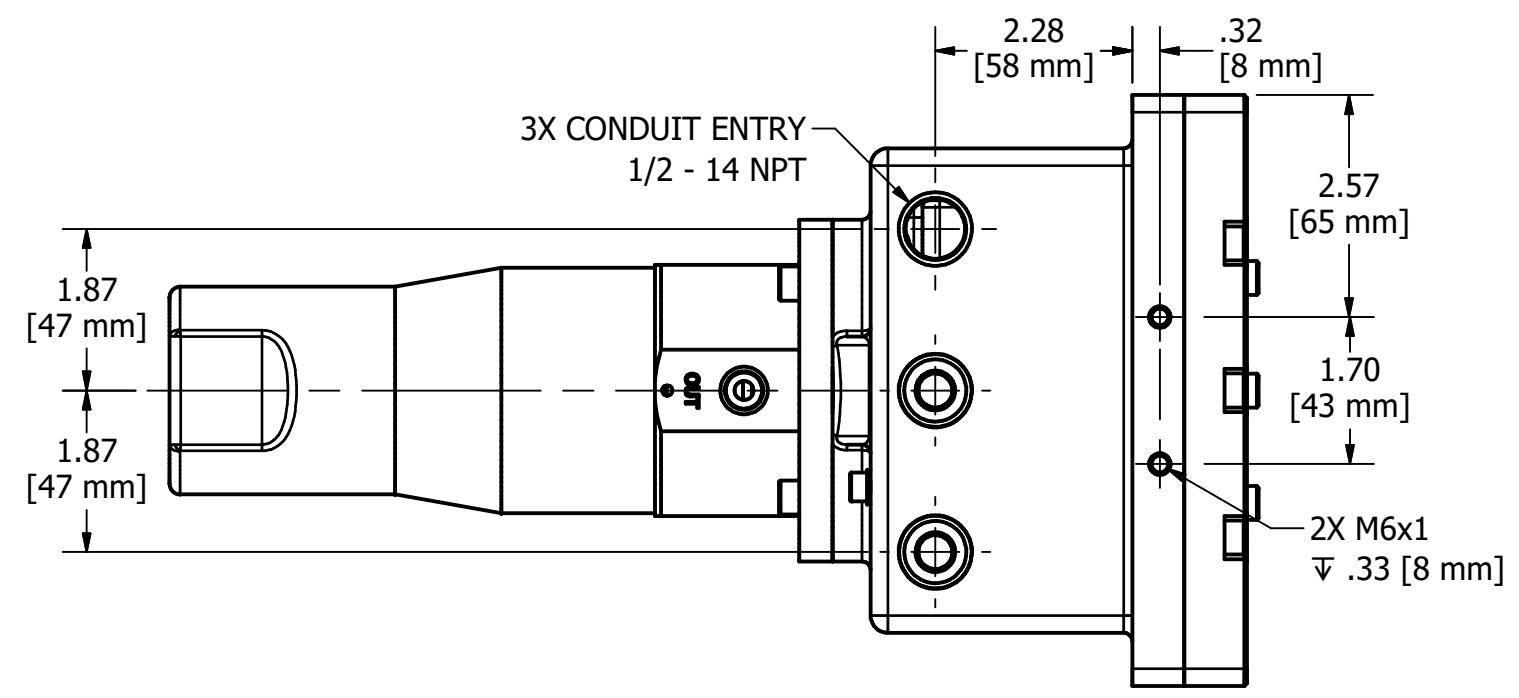
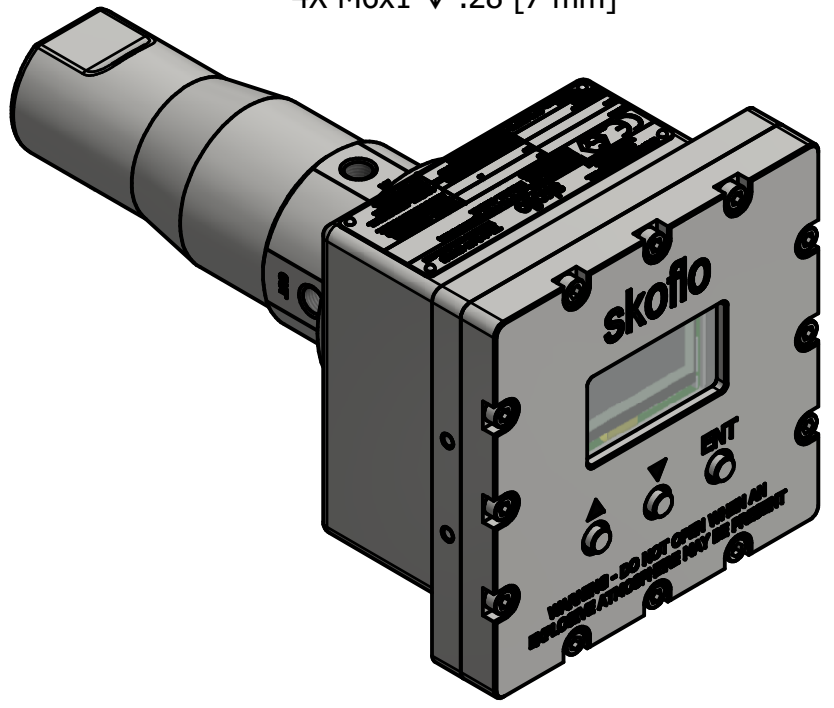
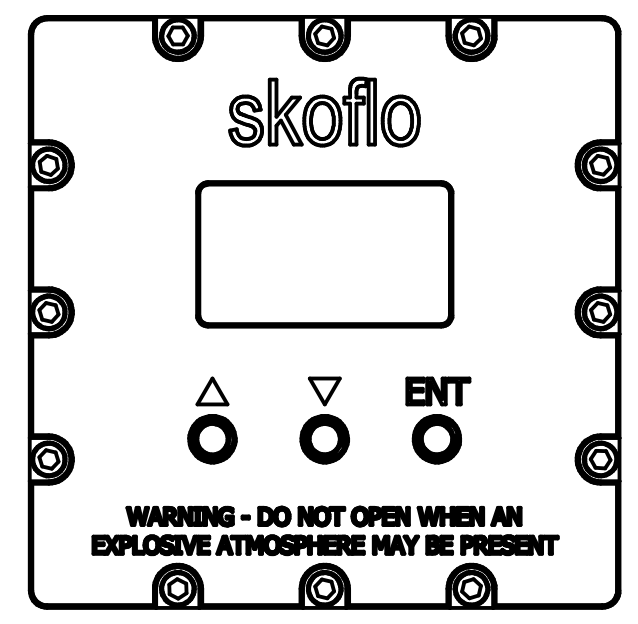
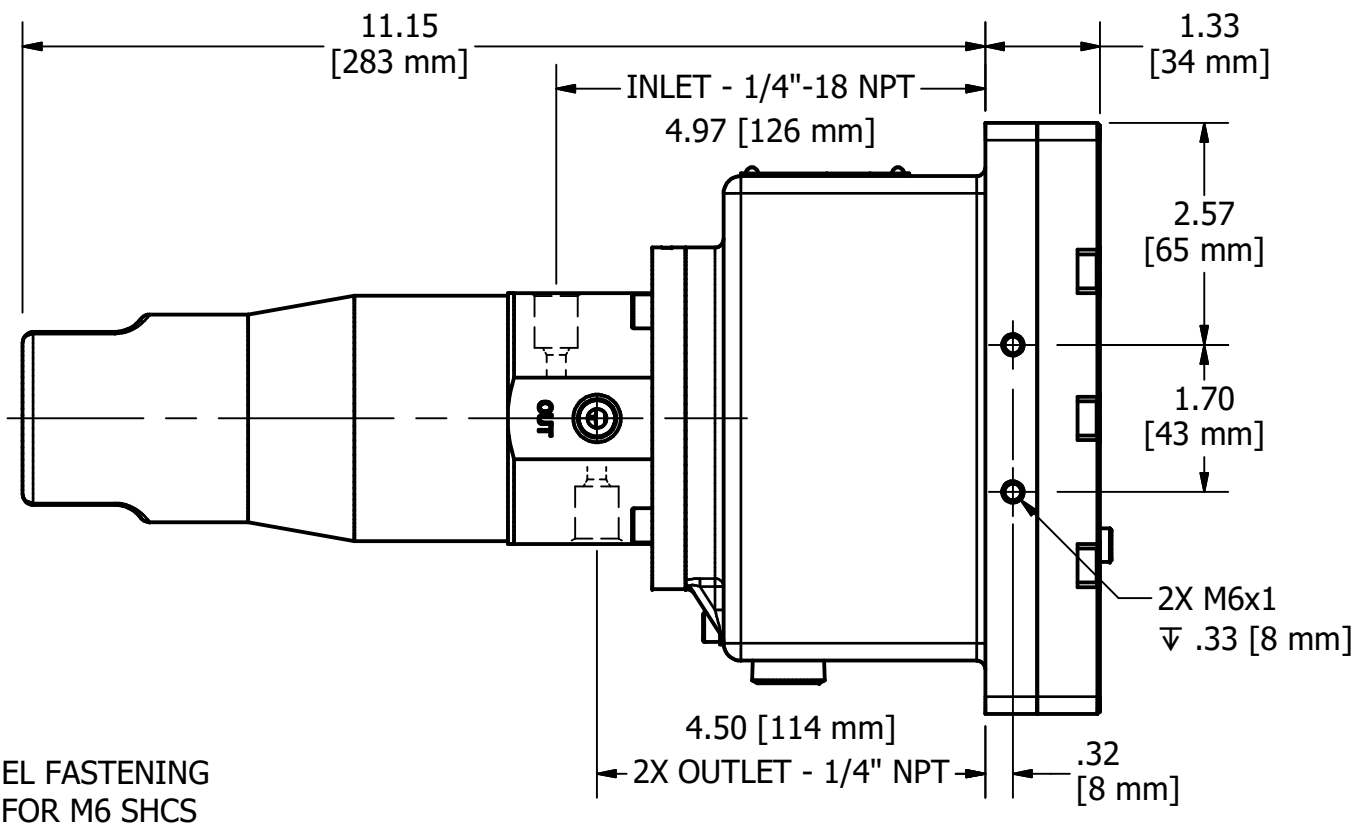
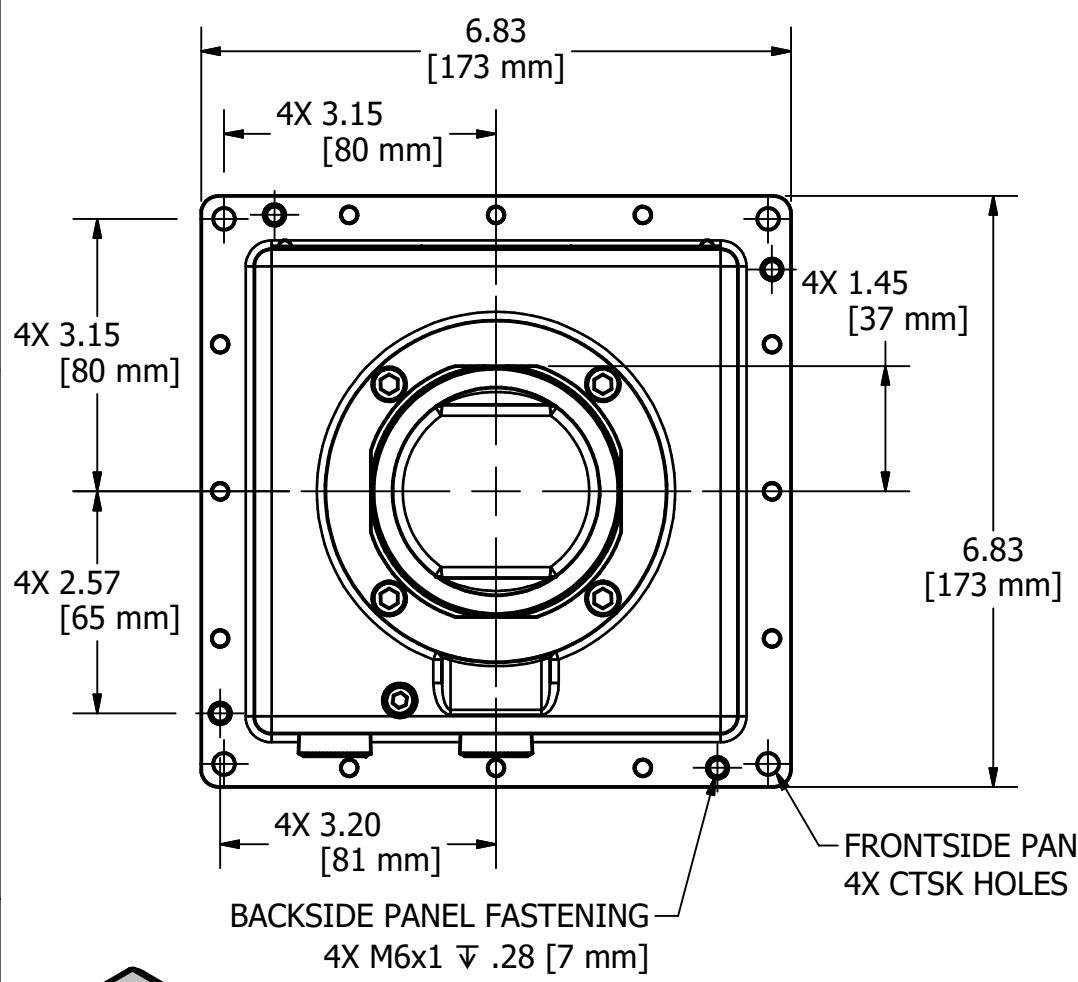

- NOTES:
- 1) NOMINAL WEIGHT = 32 lb [14.2 kg]
 - 2) RATED WORKING PRESSURE = 5,000 psi [345 bar]
 - 3) PROOF TEST PRESSURE = 7,500 psi [517 bar]
 - 4) CUTOUT FOR PANEL MOUNTING = 5.95 X 5.95 [151 mm X 151 mm]

ALL DIMENSIONS IN INCHES UNLESS OTHERWISE SPECIFIED		DRAWN J.MOORE 10/22/18	SKOFLO INDUSTRIES, INC. WOODINVILLE, WA
DRAWING PER ANSI Y14.5M-2009		ENG1 N.ALLEY 10/22/18 ENG2 S.SPAHI 10/22/18 OTHER	
FRACTIONS \pm 1/16 X \pm .03 .XX \pm .010 .XXX \pm .005 .XXX \pm .0005 ANGULAR \pm 3°	UNLESS SPECIFIED DEBURR & BREAK EDGES: .015/.005 Ra SURF QUAL: 63 FILLETS: R.020/.008 DRILL POINT: 110-150°	THIS DOCUMENT CONTAINS INFORMATION WHICH IS PROPRIETARY TO SKOFLO INDUSTRIES INC. THE INFORMATION CONTAINED HEREIN SHALL NOT BE DISCLOSED, DUPLICATED, USED IN WHOLE OR IN PART FOR ANY PURPOSE OTHER THAN TO EVALUATE THIS DOCUMENT	
		DWG NO	GA DRAWING SF5000PDFMA
		SIZE B	SCALE NONE
		SHEET 1 OF 2	