



Surface, Back Pressure Regulator 15000 psi

BPR15000B



Operations and
Maintenance Manual

TABLE OF CONTENTS

About SkoFlo	2
General Information.....	2
Hydraulic Ratings	2
Storage	3
Installation	3
Maintenance	4
Troubleshooting	7
Appendix A – BPR15000B GA and BOM Drawing.....	8

TABLE OF FIGURES

Figure 1 – Cross Section	3
Figure 2 – Piston Assembly.....	5
Figure 3 – Internal Parts Removal	5
Figure 4 – Seat Holder Installation	5
Figure 5 – O-ring Installation Kit	6
Figure 6 – Spring Stack	6

TABLE OF TABLES

Table 1 – Recommended Spare Parts	4
Table 2 – Maintenance Tool Requirements	4

ABOUT SKOFLO

Our experience and track record speak for themselves. SkoFlo has delivered over 20,000 valves since 1988. We are the only company that proves our products by testing in surface applications before deploying them subsea. The result is that SkoFlo valves have amassed over 25 million continuous operating hours. This level of experience is unparalleled and provides the basis for being the solution provider to our served market.

SkoFlo Surface Back Pressure Regulator (BPR) is the industry leader in the oil and gas marketplace and regulating pump discharge pressure in chemical injection systems.

GENERAL INFORMATION

Product Overview

The BPR is designed to maintain a constant set pressure in pump discharge lines feeding the chemical injection system. As pressure rises in the pump discharge line, the BPR will maintain pressure levels at a Set Point while allowing the unused fluid to return to the chemical holding tank.

BPRs should be used in any pump discharge line where the pressure must remain at a constant level and unused fluid can be routed back to the fluid holding tank.

BPRs are not designed to be used as pressure safety devices.

BPRs provide a constant pressure to the system with continuous spill-off to the chemical tank that is independent of the flow rate. The BPR15000B has a maximum operating pressure of 15,000psi and supports a flow ranges of 0 - 400 GPD, 0 - 800 GPD, and 100 - 2000 GPD.

Guidelines for Using this Manual

The following instructions are provided to ensure a safe and proper installation.

- Read all instructions prior to installation and operation of this product.
- Follow all warning and caution notes.
- Install this product as specified in the instructions provided by SkoFlo.
- Prior to use, educate personnel in the proper installation, operation, and maintenance of this product.
- Only use replacement parts specified by SkoFlo.

Warning, Caution, Notice

Throughout this manual there are steps and procedures which, if not followed, may result in a hazard. The following flags are used to identify the level of potential hazard.

! WARNING



WARNING IS USED TO INDICATE THE PRESENCE OF A HAZARD WHICH CAN CAUSE SEVERE INJURY, DEATH, OR SUBSTANTIAL PROPERTY DAMAGE IF THE WARNING IS IGNORED.

! CAUTION



CAUTION IS USED TO INDICATE THE PRESENCE OF A HAZARD WHICH CAN CAUSE INJURY OR PROPERTY DAMAGE IF THE WARNING IS IGNORED.

! NOTICE



NOTICE IS USED TO NOTIFY PEOPLE OF INSTALLATION, OPERATION, OR MAINTENANCE INFORMATION, WHICH IS IMPORTANT BUT NOT HAZARD RELATED.

Abbreviations and Acronyms

BOM	Bill Of Materials
BPR	Back Pressure Regulator
GA	General Assembly
GPD	Gallons Per Day
Kg/m	Kilograms per Meter
LPH	Liters Per Hour
NPT	National Pipe Thread
P/N	Part Number
psi	Pounds per Square Inch

HYDRAULIC RATINGS

! WARNING



REFER TO THE GENERAL SECTION OF THE PRODUCT DATASHEET FOR DESIGN PRESSURE DETAILS.

Max Working Pressure: 15,000 psi (1034 bar)

Hydro-Pressure: 22,5000 psi (1551 bar)

Pressure range: 4,000 to 15,000 psi (276 to 1034 bar)

Flow Ranges:

- 0 to 400 GPD (0 to 63 LPH)
- 0 to 800 GPD (0 to 126 LPH)
- 100 to 2000 GPD (16 to 315 LPH)

STORAGE

! NOTICE



IT IS RECOMMENDED TO STORE THE ASSEMBLIES IN THE SHIPPING CRATE, IF POSSIBLE.

The BPR15000B should be stored in a shelter and be protected from moisture and particulates. Storage temperatures shall be between -50°F and 158°F (-45°C and 70°C).

Any open hydraulic connections will be furnished with plastic blanking plugs.

It is important not to store the BPR15000B with production chemicals in the unit. These chemicals can settle, possibly resulting in damage to the unit. SkoFlo recommends that the valve be stored with a mixture of glycol in water as the preservation fluid.

INSTALLATION

! WARNING



WEAR PROPER PERSONAL PROTECTIVE EQUIPMENT (PPE) AS REQUIRED BY SITE SAFETY PERSONNEL WHEN INSTALLING AND TESTING.

MAINTAIN SAFE WORKING DISTANCES AS DETERMINED BY SITE SAFETY PERSONNEL WHEN TESTING.

CONSULT SKOFLO IF ANY PRODUCT CONCERNS ARISE DURING HANDLING.

! WARNING



CHEMICAL COMPATIBILITY SHALL BE DONE AND CHECKED BEFORE USE, EXCEPT FOR MEG AND WATER MIXTURES.

! WARNING



THE BPR15000B SHALL NOT BE INSTALLED SUBSEA.

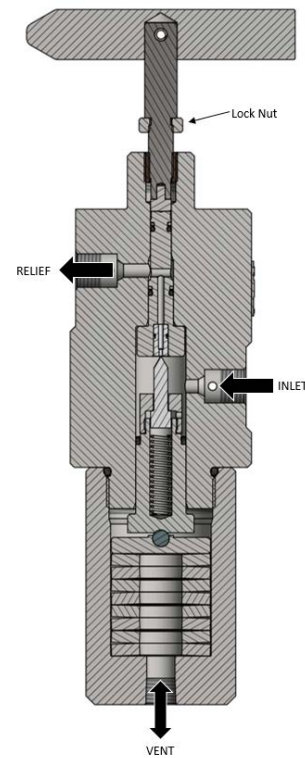

Figure 1 – Cross Section

1. Mounting

The SF5000HTVA can be panel mounted in any orientation. See Appendix B for more details.

If panel mounting, loosen the lock nut on the handle assembly, see Figure 1 – *3/8 inch wrench*, and remove the handle. Mount the valve, then replace the handle and tighten the lock nut.

2. Hydraulic Installation

! CAUTION



THE VENT FROM THE SPRING CHAMBER MUST NOT BE BLOCKED. LEAVE OPEN TO ATMOSPHERE, OR ROUTE TO A DRAIN COLLECTION POINT AT ATMOSPHERIC PRESSURE. THIS VENT WILL ONLY HAVE FLUID IN THE EVENT OF A LEAKING PISTON SEAL.

! NOTICE



INSTALL RELIEF VALVE AND/OR BURST PLATE UPSTREAM OF THE SKOFLO BACK PRESSURE REGULATOR AS REQUIRED.

! NOTICE



INSTALL A PULSATION DAMPENER BETWEEN THE PUMP DISCHARGE AND THE SKOFLO BACK PRESSURE REGULATOR AS REQUIRED TO AVOID POSSIBLE DAMAGE AND NOISE FROM HARMONIC PULSATIONS.

Install the valve so that the flow is in the proper direction. The "INLET" and "RELIEF" connections are indicated in the general arrangement drawing in Appendix A. The connections offered include the following:

- 3/8" MP Autoclave
- Ø 1/2" x 0.95" wall FKO

The "VENT" connection is 1/4" NPT and may be routed to a drain or atmospheric container if desired. The "VENT" must remain free and unrestricted and should be visible.

3. Start Up Procedures

! WARNING



ENSURE THE BPR IS FULLY OPEN (TURN THE HANDLE COUNTER-CLOCKWISE) BEFORE SUPPLYING PRESSURE

! CAUTION



DO NOT ADJUST THE VALVE FROM OPEN TO CLOSED POSITION UNLESS VALVE IS PRESSURIZED TO AVOID THE POSSIBILITY OF DISLODGING THE STEM SEAL.

- 3.1 Apply pressure to the BPR.
- 3.2 Turn the BPR pressure adjustment handle clockwise until the desired pressure is reached. Always start at a pressure below the set pressure and increase to the desired setting.
- 3.3 The BPR is now set and further adjustments are not required.
- 3.4 Tighten the lock nut (71002111) on the handle, see Figure 1, to avoid inadvertent changes to the adjustment. - 3/8" Wrench

4. Operation Notes and Warnings:

1. The SkoFlo BPR has hard seats and is not designed to provide complete "bubble-tight" shut off. Overtightening the handle will not further reduce flow. If the back pressure does not increase when turning the handle clockwise. See "Trouble Shooting Improper Valve Performance".

! CAUTION



DO NOT FLOW BACKWARDS THROUGH THE SKOFLO VALVE. INTERNAL SEALS ARE DESIGNED FOR ONE DIRECTION ONLY AND COULD POSSIBLY BECOME DISLODGED.

MAINTENANCE

! WARNING



ANY SERVICE REPAIR SHALL BE PERFORMED BY TRAINED PERSONNEL.

! NOTICE



IF ANY ABNORMALITIES ARE FOUND THROUGHOUT THE MAINTENANCE, PLEASE REPORT TO THE RESPECTIVE ENGINEERS.

5. General

Spare kits available for typical maintenance items are listed in

Table 1.

Table 1 – Recommended Spare Parts

ITEM	KIT PART NUMBER				
	EPDM	FFKM	FKM	FKMB	HNBR
Seal Kit	27474	27475	27473	27477	27476
	0-400	0-800	100-2000		
Seat Holder Kit	22013		31054		
	Spring Stack 31053				
Handle Kit	22211				
Pin	20200				

Table 2 – Maintenance Tool Requirements

Tools and Parts	Quantity
Seat Holder Installer Tool (P/N 20033)	1
O-ring Installer Tool (P/N 20103)	1
Vise	1
Parker Super Lube (or equivalent)	1

1 inch wrench	1
5/8 inch wrench	1
High Strength Locking Compound	1
3/8 inch wrench	1
1/4 inch Rod, Hex Driver, or similar tool	1

6. Replacing Base O-Ring

- 6.1 Remove the SkoFlo valve from system.
- 6.2 Secure the valve in a *vise*.
- 6.3 Unscrew and remove the base cap (20234) by hand. – *2" Wrench, if needed*
- 6.4 Take care not to drop the spring washer stack within.
- 6.5 Remove O-ring (3-920).
- 6.6 Lubricate new base O-ring (3-920). - *Parker Super Lube or equivalent*
- 6.7 Place the O-ring (3-920) onto base of threads on body.
- 6.8 Proceed to Section 10. Re-Assembly.

7. Replacing Piston Assembly Seal and Pin

- 7.1 Follow steps 6.1 - 6.3 to remove the base.
- 7.2 Remove piston assembly by hand. – *Locking Pliers, if needed*
- 7.3 Unscrew the pin holder (20238) from the piston (20237). Be careful not to drop the pin (20200) and pin spring (71002074) inside. – *1 inch wrench, 5/8 inch wrench*
- 7.4 Remove the old piston seal.
- 7.5 Lubricate the replacement piston seal (71001871). - *Parker Super Lube or equivalent*.
- 7.6 Slide the cup seal (71001871) onto the piston (20237) and make sure to orient the seal correctly with the wide end towards the pin, see Figure 2.

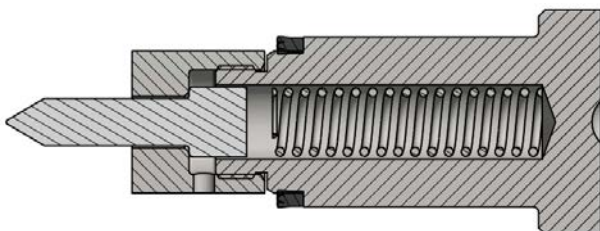

Figure 2 – Piston Assembly

- 7.7 Place the pin spring (71002074) into the piston (20237).
- 7.8 Place the replacement pin (20200) into the pin holder (20238).
- 7.9 Apply **high strength thread locking compound** to the pin holder threads, and screw onto the piston.
- 7.10 Proceed to Section 10. Re-assembly.

8. Replacing Seat Holder Assembly

When replacing seals on the Seat Holder (30925-X), it is recommended that the *Seat Holder Installer Tool (20033)* and *O-Ring Installer Tool (20103)* be used.

- 8.1 Follow steps 7.1 - 7.2 to remove the base and piston assembly.
- 8.2 Loosen the lock nut on the handle assembly, see Figure 1. – *3/8 inch wrench*
- 8.3 Remove the handle assembly (22211).
- 8.4 Slowly push the seat holder assembly out of the body, see Figure 3. - *1/4" Rod OR 1/4" Hex Key Wrench OR Similar Tool*
 - 8.4.1 Use care to avoid damage to the internal surfaces of the SkoFlo valve.

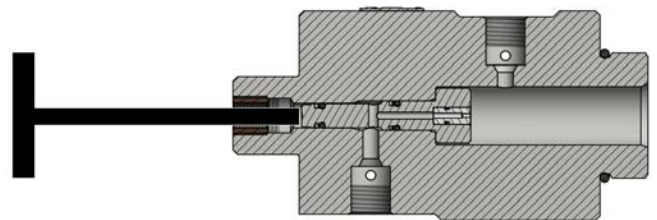

Figure 3 – Internal Parts Removal

- 8.5 Using the large end of *Seat Holder Installer Tool (20033)*, guide seat holder into the body, see Figure 4. Push the seat holder in gently using caution to avoid damaging the seals.

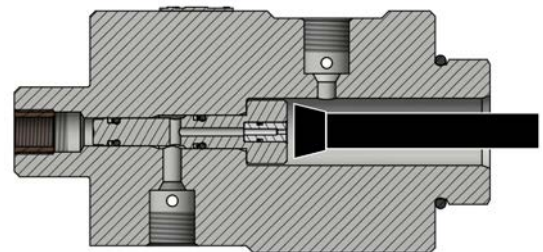

Figure 4 – Seat Holder Installation

- 8.6 Proceed to Section 10. Re-assembly.

9. Replacing Seat Holder Seals

- 9.1 Follow steps 8.1 - 8.4 to remove the seat holder assembly.
- 9.2 Remove the old seals and backup rings. Take care not to scratch any surface. – *Brass rod or pic*
- 9.3 Lubricate the new seat holder seals with *Parker Super Lube or equivalent*.
- 9.4 Slide seals onto seat holder using the *O-Ring Installer Tool*, see Figure 5. Install backup rings (orange in Figure 5) on the low pressure side of the O-rings. Make sure the backup ring is lined up at the joint.

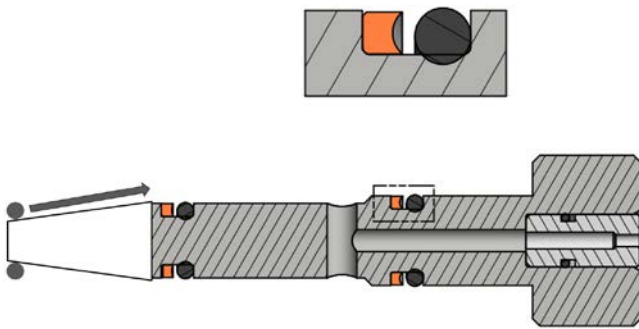

Figure 5 – O-ring Installation Kit

- 9.5 Using the large end of *Seat Holder Installer Tool*, guide seat holder into the body, see Figure 4. Use caution, push the seat holder in gently to avoid damaging the seals.
- 9.6 Proceed to Section 10. Re-assembly.

10. Re-assembly

- 10.1 Carefully slide the complete piston assembly into the valve body. Using thumb pressure with a slight wiggle motion will ease the seal into the body cavity. Push the piston into the body as far as it will go.
- 10.2 Set the spring stack assembly into the base cap such that they oppose each other, see Figure 6.

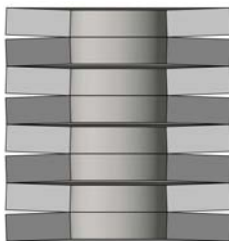
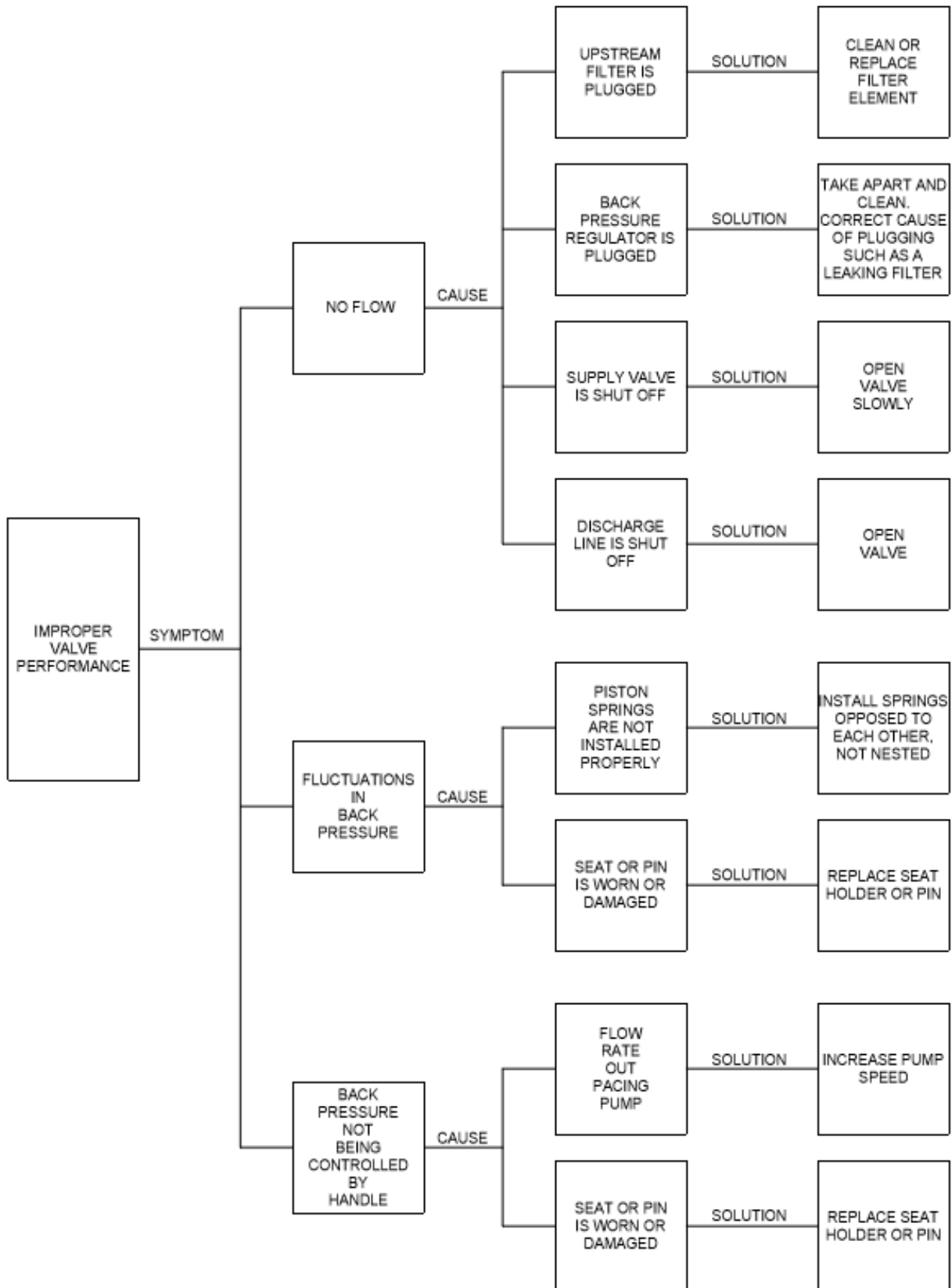

Figure 6 – Spring Stack

- 10.3 Screw base cap (20234) onto body, hand tight.
- 10.4 Install adjustment handle (22211) into the body and follow Section 2. Hydraulic Installation to commission the BPR.

TROUBLESHOOTING



Appendix A – BPR15000B GA and BOM Drawing

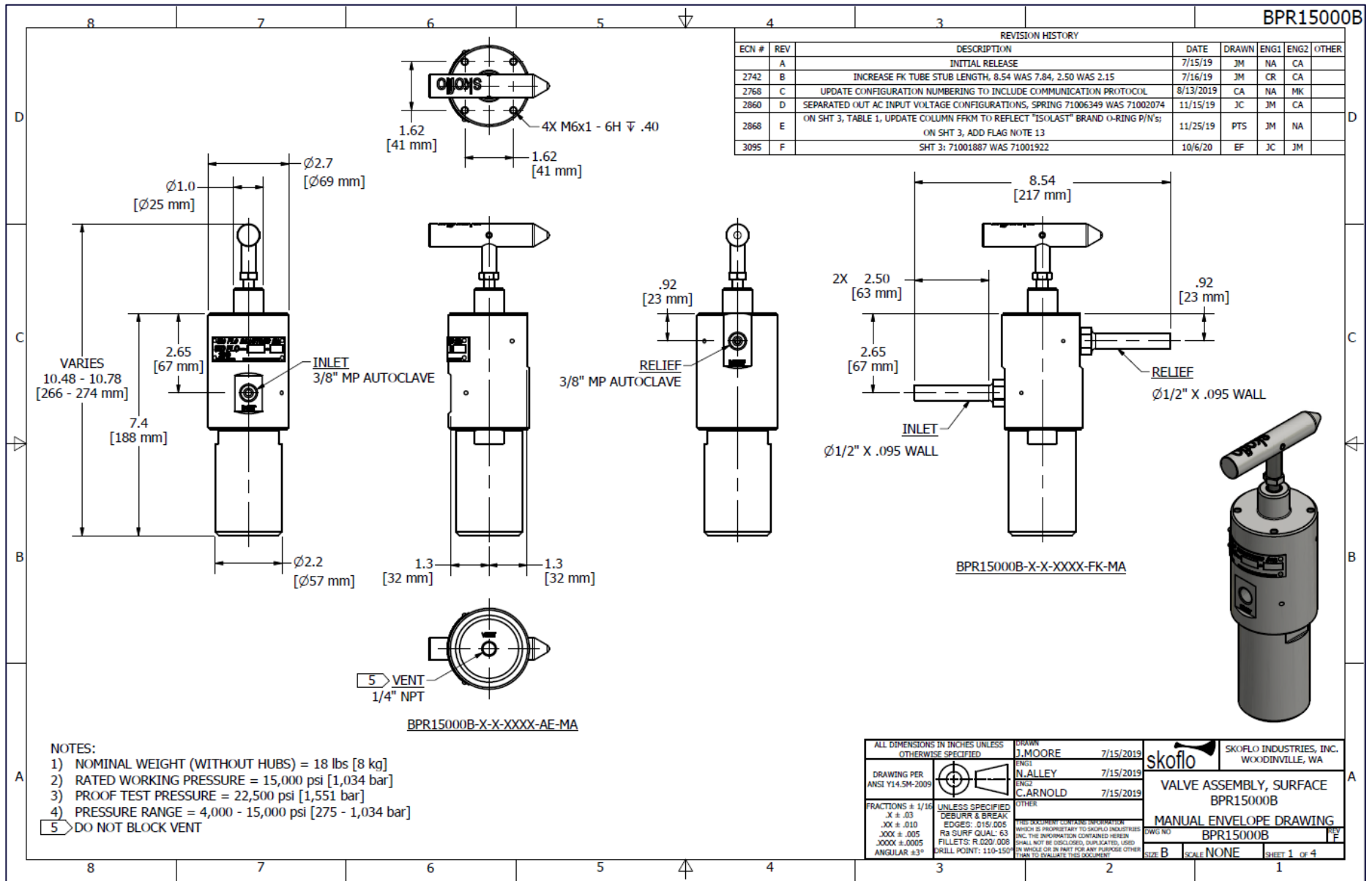

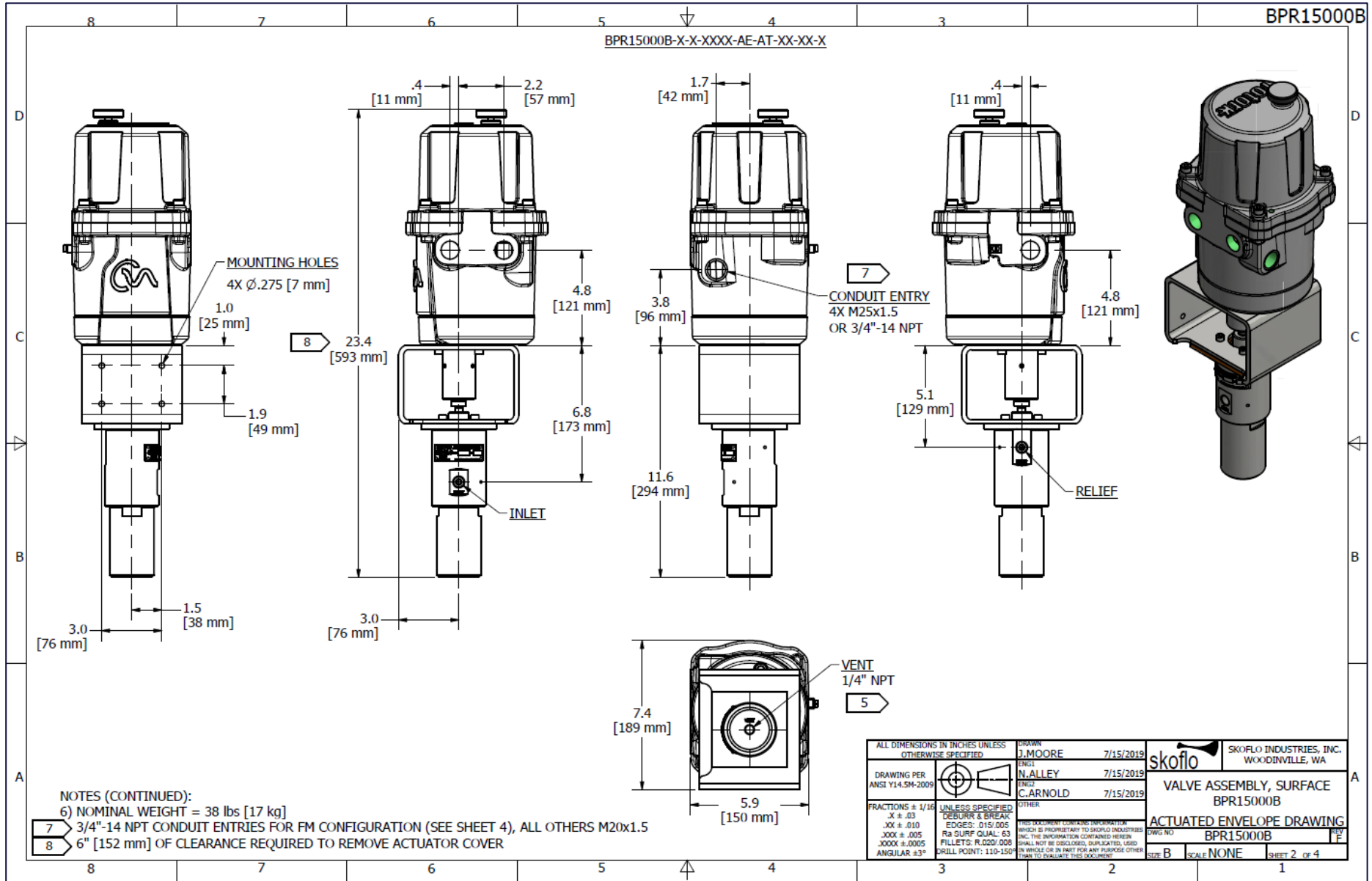

8 7 6 5 4 3
BPR15000B

MANUAL CONFIGURATION NUMBER GUIDE

BPR15000B	-	X	-	X	-	XXXX	-	XX	-	MA
4,000-15,000 psi	6	1	0-400 gpd	EPDM	AE	AUTOCLAVE				
SPRING STACK	2	2	0-800 gpd	FFKM	FK	FKO				
PRESSURE RANGE	3	3	100-2000 gpd	FKM	HYDRAULIC CONNECTION					
			FLOW RATE RANGE	FKMB						
				HNBR						
				SEAL CODE						

TABLE 1: O-RING COMPOUND SELECTION

ITEM	EPDM	FFKM	FKM	FKMB	HNBR	DESCRIPTION
16	71001729	71007009	71001730	71003553	71004919	SL, O-RING, 2-008
17	71001738	71006901	71006807	71005994	71006929	SL, O-RING, 2-010
18	71001753	71007392	71001754	71007293	71007294	SL, O-RING, 2-014

TABLE 2: FLOW RATE RANGE SELECTION

ITEM	0-400 gpd	0-800 gpd	100-2000 gpd	DESCRIPTION
19	30925-001	30925-001	30925-002	SEAT HOLDER
20	21358	21358	20121	SEAT
21	N/A	N/A	71004402	O-RING

TABLE 3: CONNECTION SELECTIONS

ITEM	AUTOCLAVE	FKO	DESCRIPTION
22	27510	31024	BODY, BPR15000B
23	N/A	31025	HUB

TABLE 4: PARTS LIST

ITEM	QTY	PART NUMBER	DESCRIPTION	MATERIAL	PRESSURE CONTAINING
1	1	10179	ASSY, WASHER, SPRING STACK, BPR, LF, SURFACE	SEE DWG 10179	NO
2	1	20096	BUSHING, THREADED (3/8 X 1/2)	AL-NI-BRZ	NO
3	1	20200	PIN, Ø.207, LONG	ZIRCONIA	NO
4	1	20234	BASE, BPR, LF, SURFACE	NITRONIC 60	YES
5	1	20237	PISTON, BPR, LF, SURFACE	NITRONIC 60	YES
6	1	20238	HOLDER, PIN, BPR, LF, SURFACE	316L SS	NO
7	1	22211	HANDLE, ASSY, COMPLETE, BPR, LF, SURFACE	SEE DWG 22211	NO
8	1	71001833	SL, ORING, 3-920	EPDM	NO
9	1	71001871	SL, CLIP, .75 OD X .625 ID	SEE DWG 71001871	YES
10	1	71001887	SL, BU RING, .008, SCARF CUT	PTFE	NO
11	1	71001924	SL, BU RING, 8-010	PEEK	NO
12	1	71006349	SPRING, COIL, Ø.304 X 1.94, PIN, BPR LF SUBSEA	ELGILOY	NO
13	4	71002116	U-DRIVE SCREW, RH, #2X1/4	302 SS	NO
14	1	71002143	NAMEPLATE, BPR15000/SF15000	316L SS	NO
15	8	71005992	SPRING, WASHER, Ø1.480 OD x Ø.625 ID, .177 TH	INCONEL X-750	NO
16	1	SEE TABLE 1	SL, O RING, 2-008	SEE TABLE 1	YES
17	1	SEE TABLE 1	SL, O-RING, 2-010	SEE TABLE 1	NO
18	2	SEE TABLE 1	SL, O RING, 2-014	SEE TABLE 1	YES
19	1	SEE TABLE 2	HOLDER, SEAT, BPR5000D/10000C/15000B, SURFACE	NITRONIC 50 HS	YES
20	1	SEE TABLE 2	SEAT	ALUMINA	NO
21	1	SEE TABLE 2	SL, O RING, M1 X 8, FFKM	SEE TABLE 2	NO
22	1	SEE TABLE 3	BODY, BPR15000B	NITRONIC 50 HS	YES
23	2	SEE TABLE 3	HUB, 1-12 UNF, Ø1/2" X .095 WALL	SUPER DUPLEX 2507	YES

NOTES (CONTINUED):

9) COAT ALL THREADS WITH DYNATEX ANTI-SEIZE & LUBRICATING COMPOUND (OR SIMILAR) UNLESS OTHERWISE STATED

10) LUBRICATE ALL SEALS WITH PARKER SLUBE 884-4 (OR SIMILAR)

11) SEE BPR15000B-INTERNAL FOR SPARES KITS PART LISTS

12) ITEM 18 IS NOT REQUIRED FOR AUTOCLAVE CONFIGURATION

13) PRESSURE CONTAINING FFKM O-RINGS SHALL BE "ISOLAST" GRADE J9523

8 7 6 5 4 3
DRAWN: J. MOORE 7/15/2019
ENGR: N. ALLEY 7/15/2019
ENGR: C. ARNOLD 7/15/2019

ALL DIMENSIONS IN INCHES UNLESS OTHERWISE SPECIFIED

DRAWING PER ANSI Y14.5M-2009

FRACTIONS ± 1/16
X ± .03
.XX ± .010
.XXX ± .005
XXXX ± .0005

UNLESS SPECIFIED
DEBURR & BREAK
EDGES: .015/005
RA SURF QUAL: 63
FILLETS: R.000/008
DRILL POINT: 110-150°
ANGULAR: 43°

skoflo

VALVE ASSEMBLY, SURFACE
BPR15000B
MANUAL BOM
BPR15000B

SIZE B SCALE NONE SHEET 3 OF 4

SKOFLLO INDUSTRIES, INC.
WOODDINVILLE, WA

THIS DOCUMENT CONTAINS INFORMATION PROPRIETARY TO SKOFLLO INDUSTRIES, INC. THE INFORMATION CONTAINED HEREIN SHALL NOT BE DISCLOSED, REPRODUCED, USED IN WHOLE OR IN PART FOR ANY PURPOSE OTHER THAN TO EVALUATE THIS DOCUMENT.

ACTUATED CONFIGURATION NUMBER GUIDE

BPR15000B	-	X	-	X	-	XXXX	-	XX	-	XX	-	XX	-	X	-	XX
4,000-15,000 psi SPRING STACK PRESSURE RANGE	6	1 0-400 gpd 2 0-800 gpd 3 100-2000 gpd FLOW RATE RANGE		EPDM FFKM FKM FKMB HNBR SEAL CODE		AE AUTOCLAVE FK FKO HYDRAULIC CONNECTION		MA MANUAL AT ACTUATOR ACTUATOR SELECTION		120 120 VAC 208 208 VAC 230 230 VAC DC 24VDC VOLTAGE SELECTION		4 4 - 20 mA F FIELD BUS H HART COMMUNICATION PROTOCOL		NA FM AX ATEX EX IECEx GO GOST HAZLOC SELECTION		

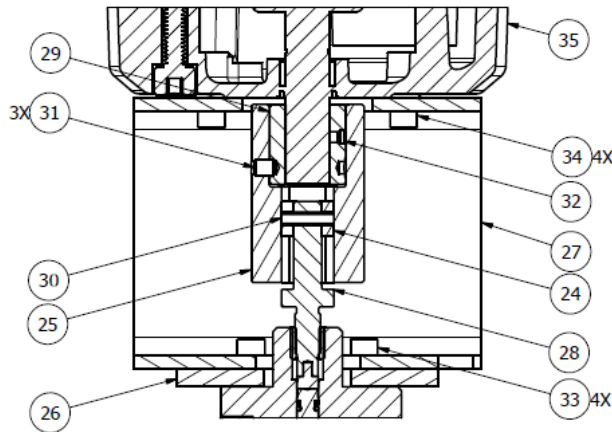

PARTS LIST					
ITEM	QTY	PART NUMBER	DESCRIPTION	MATERIAL	PRESSURE CONTAINING
24	1	20680	ADAPTER, SQUARE DRIVE, ACTUATOR	316 SS	NO
25	1	26540	COUPLER, ACTUATOR, SQUARE DRIVE	NITRONIC 50 HS	NO
26	1	27398	PLATE, ADAPTER, MOUNTING, ACTUATOR	316SS	NO
27	1	27430	BRACKET, ACTUATOR, BPR10000C/ 15000B	316L SS	NO
28	1	27480	STEM, ACTUATOR, SF15000C	SEE DWG 27480	NO
29	1	30802	SLEEVE, ADAPTER, ACTUATOR	316L SS	NO
30	1	71002082	RLPN, Ø.1875 X 0.75 LG	316 SS	NO
31	3	71002101	SHSS, CUP, M6-1 X 8	316 SS	NO
32	1	71002911	SHSS, CUP, 10-32 X 1/8	316 SS	NO
33	4	71007102	SHCS, M6X1 - 20	316 SS	NO
34	4	71007246	SHCS, M6X1 X 12LG	316 SS	NO
35	1	SEE DWG 71007126	ACTUATOR, ROTARY, CMR-200	SEE DWG 71007126	NO

ALL DIMENSIONS IN INCHES UNLESS OTHERWISE SPECIFIED DRAWING PER ANSI Y14.5M-2009 FRACTIONS ± 1/16 .X ± .03 .XX ± .010 .XXX ± .005 .XXXX ± .0005 ANGULAR ±3°		DRAWN: J. MOORE 7/15/2019 FIRST: N. ALLEY 7/15/2019 ENG'D: C. ARNOLD 7/15/2019 OTHER:	SKOFLIO INDUSTRIES, INC. WOODINVILLE, WA VALVE ASSEMBLY, SURFACE BPR15000B ACTUATED BOM BPR15000B SHEET 4 OF 4
--	--	--	--

NOTES (CONTINUED):
 14) ITEM 7 IS NOT REQUIRED FOR ACTUATED CONFIGURATION



SkoFlo Industries
14241 NE 200th Street
Woodinville, WA 98072 USA
Tel 1-425-485-7816
Fax 1-425-368-1696

www.SkoFlo.com