



# Surface, Pressure Independent Flow Controller 10000psi

SF10000NMFE



Operations and  
Maintenance Manual

## TABLE OF CONTENTS

About SkoFlo .....	2
General Information.....	2
Hydraulic Ratings .....	3
Storage .....	3
Installation .....	4
1. Mounting .....	4
2. Hydraulic Installation.....	4
3. Start Up Procedures.....	4
4. Adjustment and Calibration .....	4
Maintenance .....	4
6. Replacing the Stem Assembly .....	5
7. Replacing the Stem Assembly Seals.....	6
8. Replacing Base Cap Seals.....	7
9. Replacing Piston Seals.....	7
10. Replacing large springs.....	8
11. Replacing Seat Retainer Seals.....	8
12. Replacing Seat Seals.....	8
13. Closing the valve.....	9
14. Replace hex plug seal .....	9
15. Replace hub seals .....	9
Troubleshooting .....	10
Appendix A – A Typical Chemical Injection System .....	11
Appendix B – SF10000NMFE GA and BOM Drawing.....	12

## TABLE OF FIGURES

Figure 1 – SF10000NMFE Cross Section View.....	2
Figure 2 – Valve Components .....	5
Figure 3 - Handle Assembly .....	6
Figure 4 – Stem O-Ring Installation.....	6
Figure 5 – Trim Removal.....	6
Figure 6 – Stem Trim.....	7
Figure 7 – Base Cap .....	7
Figure 8 - Piston Assembly .....	8
Figure 9 – Spring Orientation .....	8
Figure 10 – Seat Retainer Assembly.....	8
Figure 11 – Seat Removal.....	8
Figure 12 – Seat Assembly.....	9

## TABLE OF TABLES

Table 1 – SF10000NMFE Spares Kit Part Numbers .....	5
Table 2 – Tools and Parts .....	5
Table 3 – Hub Wrenches.....	5

## ABOUT SKOFLO

Our experience and track record speak for itself. SkoFlo has delivered over 20,000 valves since 1988. We are the only company that proves our products by testing in surface applications before deploying them subsea. The result is that SkoFlo products have amassed over 25 million continuous operating hours. This level of experience is unparalleled and provides the basis for being the solution provider to our served market.

## GENERAL INFORMATION

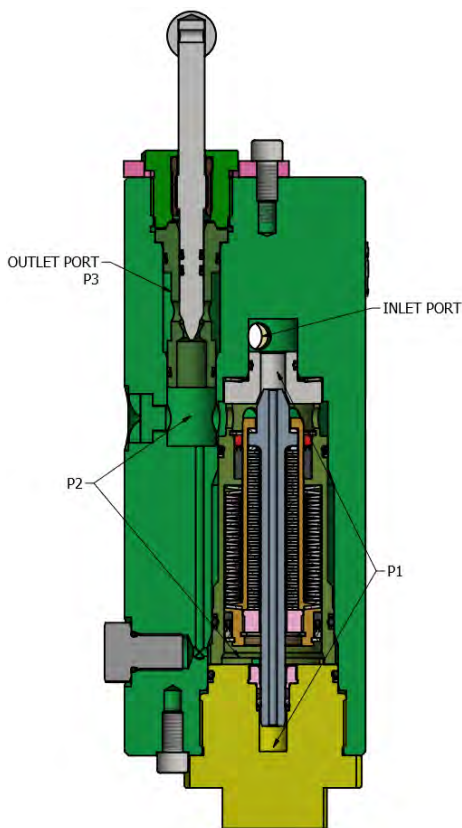

**Figure 1 – SF10000NMFE Cross Section View**

### Product Overview

The SF10000NMFE is a pressure independent chemical injection and metering valve (CIMV), used in the petroleum industry to accurately control chemical injection rates. The SF10000NMFE regulates flow to counter pressure changes on the inlet and outlet of the unit. This is referred to as “pressure independence”.

### Pressure Independence

SkoFlo defines pressure independence as the percent (%) of reading change for each 1,000 psi (69 bar) change in supply or outlet pressure.

Pressure independence in the SF10000NMFE is a completely mechanical process, requiring zero power.

The principle of pressure independence is that the valve maintains a constant differential pressure (dP) across an orifice thus resulting in a constant flow rate through that orifice.

The pressure that is generated by flow through the orifice is applied to either side of a spring balanced piston that carries a regulating pin. The piston will travel to a position where the spring force equals the pressure force.

### Minimum Differential Pressure

For the SF10000NMFE to provide pressure independent performance, a minimum differential pressure (min dP) is required across the valve to allow the spring-balanced piston to move to a truly balanced location.

In general, high flows and/or viscosities require a higher min dP across the valve. Refer to the product datasheet for specific information.

### Guidelines for Using this Manual

The following instructions are provided to ensure a safe and proper installation and operation.

- Read all instructions prior to installation and operation of this product.
- Follow all warning and caution notes.
- Install this product as specified in the instructions provided by SkoFlo Industries, Inc.
- Prior to use, educate personnel in the proper installation, operation, and maintenance of this product.
- Only use replacement parts specified by SkoFlo Industries, Inc.

**Warning, Caution, Notice**

Throughout this manual there are steps and procedures which, if not followed, may result in a hazard. The following flags are used to identify the level of potential hazard.

**! WARNING**

WARNING IS USED TO INDICATE THE PRESENCE OF A HAZARD WHICH CAN CAUSE SEVERE INJURY, DEATH, OR SUBSTANTIAL PROPERTY DAMAGE IF THE WARNING IS IGNORED.

**! CAUTION**

CAUTION IS USED TO INDICATE THE PRESENCE OF A HAZARD WHICH CAN CAUSE INJURY OR PROPERTY DAMAGE IF THE WARNING IS IGNORED.

**! NOTICE**

NOTICE IS USED TO NOTIFY PEOPLE OF INSTALLATION, OPERATION, OR MAINTENANCE INFORMATION, WHICH IS IMPORTANT BUT NOT HAZARD RELATED.

**Abbreviations and Acronyms**

CIMV Chemical Injection and Metering Valve

dP Differential Pressure

GA General Arrangement

GPM Gallons Per Minute

NMFE Needle Medium Flow Generation E

NPT National Pipe Thread

SHCS Socket Head Cap Screw

P/N Part Number

psi Pounds per Square Inch

**HYDRAULIC RATINGS****! WARNING**

REFER TO THE GENERAL SECTION OF THE PRODUCT DATASHEET FOR DESIGN PRESSURE DETAILS.

**! NOTICE**

OPERATING VALVE WITH CONTINUOUS DIFFERENTIAL PRESSURES ABOVE 6000 PSI / 415 BAR MAY CAUSE PREMATURE INTERNAL WEAR AND MUST BE AVOIDED.

**! NOTICE**

THE SF10000NMFE REQUIRES A MINIMUM DIFFERENTIAL PRESSURE ACROSS THE VALVE OF 500 PSI (35 BAR) TO ACHIEVE FULL RATED FLOW.

Max Working Pressure: 10,000 psi (689 bar)

Hydro-Pressure: 15,000 psi (1034 bar)

Flow Rate Ranges:

- 0.1 – 2 GPM
- 0.25 – 12 GPM

Min Differential Pressure: 500psi (35 bar)

**STORAGE****! NOTICE**

IT IS RECOMMENDED TO STORE THE ASSEMBLIES IN THE SHIPPING CRATE, IF POSSIBLE.

The SF10000NMFE should be stored in a shelter and be protected from moisture and particulates. Storage temperatures shall be between -50°F and 158°F (-45°C and 70°C).

Any open hydraulic connection will be furnished with plastic blanking plugs.

It is important not to store the SF10000NMFE with production chemicals in the unit. These chemicals can settle, possibly resulting in damage to the unit. SkoFlo recommends that the valve be stored with a mixture of glycol in water as the preservation fluid.

## INSTALLATION

### ! WARNING



CHEMICAL COMPATIBILITY SHALL BE DONE AND CHECKED BEFORE USE, EXCEPT FOR MEG AND WATER MIXTURES.

### ! WARNING



THE SF10000NMFE SHALL NOT BE INSTALLED SUBSEA.

### 1. Mounting

The SF10000NMFE can be panel or side mounted. The SF10000NMFE can be panel mounted via the four M8x1.25 holes on the top of the valve, or the two M12x1.75 holes on each side. See Appendix B for more details.

If panel mounting, unscrew the handle fastener with a 4mm Allen wrench and remove the handle. Mount the valve, then replace the handle and tighten the fastener in place.

### 2. Hydraulic Installation

Install the SF10000NMFE so that the flow is in the proper direction. The IN (inlet) and OUT (outlet) connections are marked respectively. See Appendix B for details.

Install an inline filter upstream of the SF10000NMFE. Clean chemicals and proper filtering are very important. Omitting the filter can cause the valve to become plugged. A 200 micron size filter is recommended. Note: if coarser filters are used, the adjustment handle may need to be periodically opened to flush out any debris.

A pulsation dampener is recommended to be installed on the inlet header supplying the SF10000NMFE for improved longevity and set point consistency. A bladder type pulsation dampener is preferred over a piston type. Reactive dampeners that use baffles will do little to dampen the pressure over the full flow range of the valve.

The SF10000NMFE is not a positive shut off device, therefore, a valve on the inlet or outlet will be required to meet shut off specifications. The preferred location of the shut off valve is on the outlet of the SkoFlo valve to minimize the shock to internal parts during start up.

A check valve shall be installed immediately downstream of the SF10000NMFE (within 5 feet) to prevent well fluids entering the valve. Check valve cracking pressure is recommended to be under 10 psi to enhance longevity of check valve seats.

An example of a typical chemical injection system is given in Appendix A.

### 3. Start Up Procedures

- 3.1 Open the supply isolation valve to the SkoFlo valve slowly (> 1 second). This will allow pressures within the unit to equalize slowly; the valve will stabilize quickly.
- 3.2 Turn the rate adjustment handle clockwise until you are at the desired flow rate.
- 3.3 Always start at a flow rate above the desired flow and decrease to the desired setting (turn handle clockwise to decrease flow rate).
  - For the most consistent set point results, rotate handle ½ a turn clockwise to reach the set point.
- 3.4 The flow controller is now set, and further adjustments are not required.

### 4. Adjustment and Calibration

The SF10000NMFE is a pressure independent flow control device. Once the valve is set at a desired flow rate, that flow rate is maintained even though the pressure conditions upstream and/or downstream of the valve may change considerably.

The flow rate can be set using an inline flow meter, however, it must be capable of withstanding the process pressure.

## MAINTENANCE

### ! WARNING



ANY SERVICE REPAIR SHALL BE PERFORMED BY TRAINED PERSONNEL.

### ! NOTICE



IF ANY ABNORMALITIES ARE FOUND THROUGHOUT THE MAINTENANCE, PLEASE REPORT TO THE RESPECTIVE ENGINEERS.

## 5. General

Spares kits available for typical maintenance items are listed in Table 1.

**Table 1 – SF1000NMFE Spares Kit Part Numbers**

ITEM	P/N	
Large Spring Set	31061	
EPDM Seal Kit	27413	
FFKM Seal Kit	27416	
FKM Seal Kit	27412	
HNBR Seal Kit	23008	
Cup Seal Installation Tool	30066	
Stem Kit	0.1 – 2 GPM	31063
	0.25 – 12 GPM	22294
Stem Trim	0.1 – 2 GPM	27135
	0.25 – 12 GPM	20674
Seat	0.1 – 2 GPM	27711
	0.25 – 12 GPM	27359

**Table 2 – Tools and Parts**

Tools and Parts
Vise
Torque wrench (up to 200ft.lbs)
Various wrenches
Various hex wrenches
1-3/8 in Crowfoot Wrench Drive
Wrench for specialized hubs (See Table 3)
Brass hooked probe
Parker Super Lube (or equivalent)
Dynatex Anti-Seize and Lubricating Compound (or equivalent)
Medium Strength Locking Compound

**Table 3 – Hub Wrenches**

Hub Type	Wrench Needed
FKO	30mm Extra Long Socket
¾ MP AE	1-1/4 Crowfoot Wrench Drive
Graylock 1GR4/5/7	1-3/8 in Crowfoot Wrench Drive

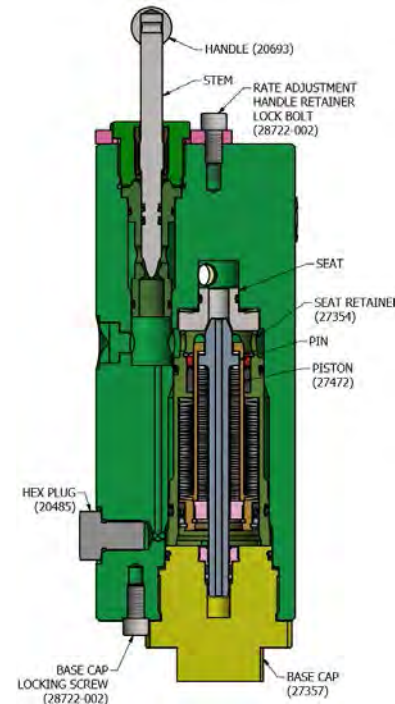
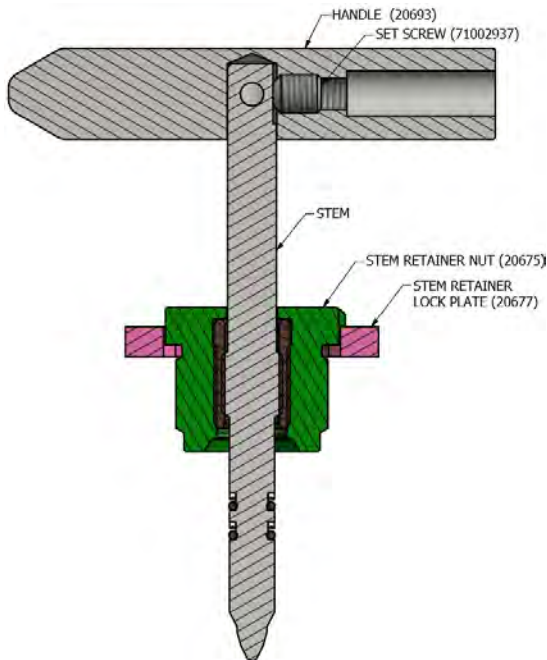

**Figure 2 – Valve Components**

## 6. Replacing the Stem Assembly

- 6.1 Remove SkoFlo valve from system.
- 6.2 Secure the valve in a vise.
- 6.3 The set screw in the handle was fixed in place with medium strength locking compound and will resist movement but will break loose with firm steady pressure. Unscrew the set screw (71002937) in the handle and pull the handle (20693) off the stem. – *4mm Allen Wrench*





**Figure 3 - Handle Assembly**

- 6.4 Remove the adjustment handle retainer lock bolt (28722-002). Remove the retainer lock plate (20677). – *6mm Allen Wrench*
- 6.5 Unscrew the stem retainer nut (20675) and pull the stem and nut out of the body. The stem retainer nut (20677) and the stem will remain together during this step. – *1-3/8 Wrench*
- 6.6 Rotate the stem clockwise to release it from the stem retainer nut.
- 6.7 Screw the replacement stem into the stem retainer through the bottom of the retainer.

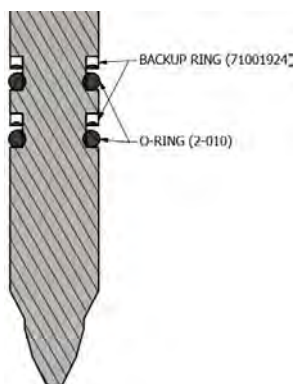

**Figure 4 - Stem O-Ring Installation**

- 6.8 Lubricate the replacement O-rings with *Parker Super Lube or similar*.

- 6.9 Place the backup rings onto the stem so the contour faces the O-ring. Install per Figure 4.
- 6.10 Place the handle onto the replacement stem such that the set screw will land on the flat of the stem.
- 6.11 Put medium strength locking compound onto the set screw. Place it into the handle and tighten.
- 6.12 Follow steps 7.8-7.10 to install adjustment handle stem assembly.

## 7. Replacing the Stem Assembly Seals

- 7.1 Follow steps 6.1-6.5 to remove the stem assembly.
- 7.2 Pull out the stem trim (see Figure 5). Use care to avoid damage to the internal surfaces of the SkoFlo valve. – *Brass hooked probe*
- 7.3 Remove the old O-rings and backup rings on the stem and trim.

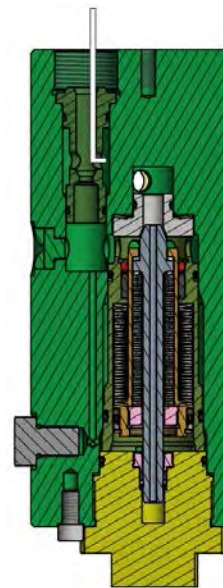

**Figure 5 - Trim Removal**

- 7.4 Lubricate the replacement O-rings with *Parker Super Lube or similar*.
- 7.5 Install the backup rings so that the contour faces the O-ring.
- 7.6 Install the stem backup rings and O-rings per Figure 4.
- 7.7 Install the external backup rings and O-rings per Figure 6.

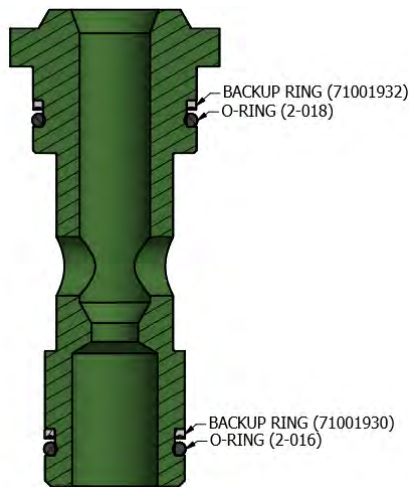
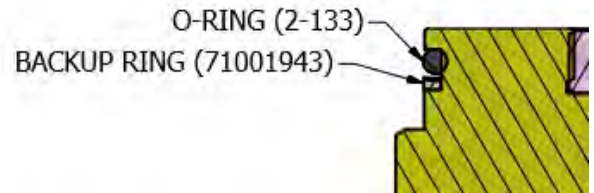
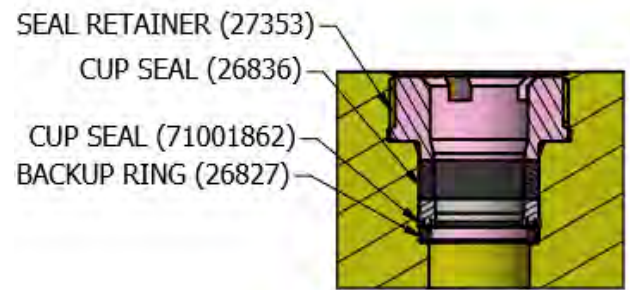

**Figure 6 – Stem Trim**

- 7.8 Place the stem trim and adjustment handle assembly into the body.
- 7.9 Orient the stem retainer so that the retainer lock plate and retainer lock bolt will fit in place. – *1-3/8 Wrench*
- 7.10 Install the lock bolt into the body to retain the lock plate. – *6mm Allen Wrench*

## 8. Replacing Base Cap Seals

- 8.1 Remove SkoFlo valve from system.
- 8.2 Secure the valve in a *vis*.
- 8.3 Unscrew and remove the base cap locking screw (28722-002). – *6mm Allen Wrench*
- 8.4 Unscrew and remove the base cap (27357). – *1.5in or 38mm Socket or Wrench*
- 8.5 Unscrew the seal retainer (27353). – *large flat head screwdriver*
- 8.6 Remove the internal backup ring and cup seal. – *Brass hooked probe*
- 8.7 Lubricate the replacement cup seal (71001862) with *Parker Super Lube or similar*.



**Figure 7 – Base Cap**

- 8.8 Install the retaining ring (26827) such that the ridge faces away from the hex.
- 8.9 Install the cup seal into the base cap with the spring side facing towards the hex.
- 8.10 Install the backup ring (26836).
- 8.11 Thread the seal retainer (27353) into the base cap and tighten with a *large flathead screwdriver*.
- 8.12 Remove old external O-ring and backup ring.
- 8.13 Lubricate replacement O-ring with *Parker Super Lube or equivalent*.
- 8.14 Install the backup rings so that the concave contour faces the O-ring. Install the backup ring and O-ring per Figure 7.
- 8.15 Go to 13.Closing the valve.

## 9. Replacing Piston Seals

- 9.1 Follow steps 8.1-8.4
- 9.2 Carefully pull out the piston assembly and the large spring stack (see Figure 8).
- 9.3 Remove piston snap ring retainer (71005981), seal retainer (27355), and cup seal (71001872).
- 9.4 Lubricate new piston cup seal with *Parker Super Lube or equivalent*.
- 9.5 Slide cup seal onto piston, then the seal retainer. Be sure to orient the seals correctly – the spring side of the cup seal should face the



base of the valve, the seal retainer ridged edge should face the cup seal spring (see Figure 8).

- 9.6 Install the snap ring (71005981).

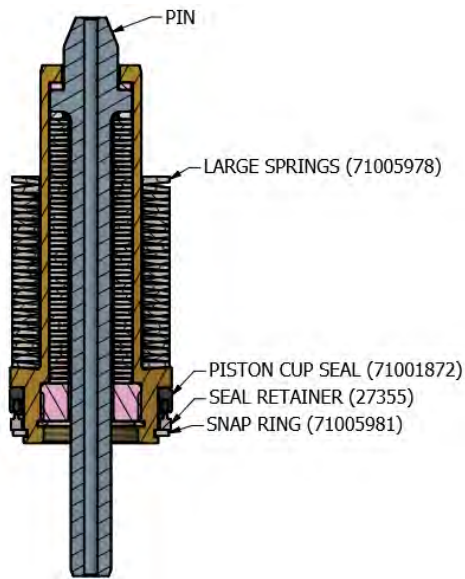

**Figure 8 - Piston Assembly**

- 9.7 Go to 13. Closing the valve.

**10. Replacing large springs**

- 10.1 Follow step 9.1-9.2.
- 10.2 Remove the large washer springs (71005990).
- 10.3 Place replacement large washer springs onto the piston assembly such that they oppose each other – concave to concave, convex to convex (see Figure 9).

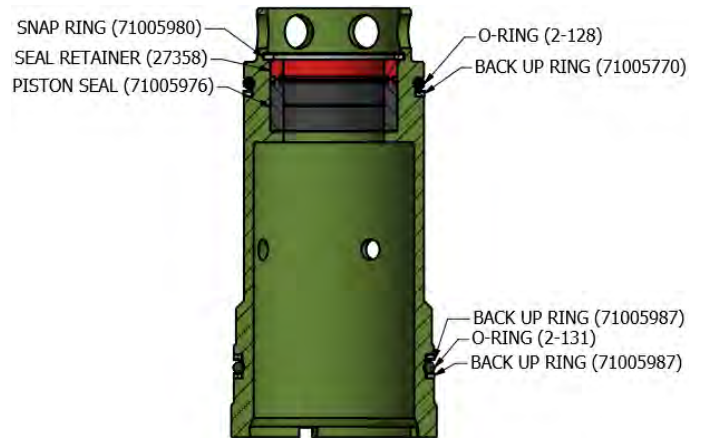

**Figure 9 – Spring Orientation**

- 10.4 Go to 13. Closing the valve.

**11. Replacing Seat Retainer Seals**

- 11.1 Follow steps 9.1-9.2.
- 11.2 Remove seat retainer assembly (27354).
- 11.3 Remove the old external seals.
- 11.4 Remove internal snap ring (71005980), seal retainer (27358), cup seal (71005976), and backup ring.
- 11.5 Lubricate the replacement cup seal with *Parker Super Lube or equivalent*.

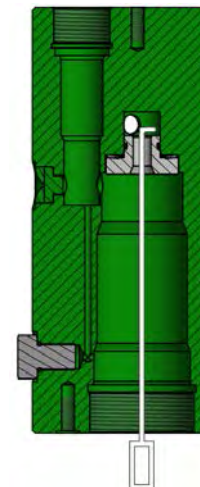

**Figure 10 – Seat Retainer Assembly**

- 11.6 Install the replacement backup ring, then the replacement cup seal with spring side visible. – *Cup Seal Installation Tool (30066)*
- 11.7 Install seal retainer (27358) with the raised ridge against the cup seal spring.
- 11.8 Install the snap ring.
- 11.9 Lubricate the replacement O-rings with *Parker Super Lube or equivalent*.
- 11.10 Install the backup rings so that the contour faces the O-ring. Install the replacement backup rings and O-rings per Figure 10.
- 11.11 Go to 13. Closing the valve.

**12. Replacing Seat Seals**

- 12.1 Follow steps 11.1-11.2.
- 12.2 Remove the seat retainer.



**Figure 11 – Seat Removal**

- 12.3 Carefully remove the seat (see Figure 11). – *Brass hooked probe*
- 12.4 Remove the old O-ring and backup ring.
- 12.5 Lubricate the replacement O-ring with *Parker Super Lube or equivalent*.
- 12.6 Install the backup ring so that the concave contour faces the O-ring. Install the backup ring and O-ring per Figure 12.

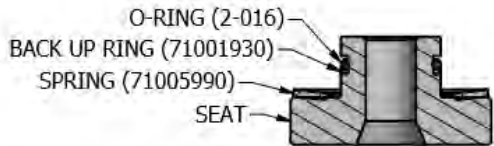

**Figure 12 – Seat Assembly**

- 12.7 Insert the seat into the body by slowly pushing with a tool which will not chip the ceramic seat. Orient the seat with smallest diameter end into the body (see Figure 11).
- 12.8 Go to 13. Closing the valve.

### 13. Closing the valve

- 13.1 If needed, ensure that the seat is placed in the valve per Figure 11.
- 13.2 If needed, re-install seat retainer so that the internal seals are facing the seat.
- 13.3 If needed, re-install piston with large springs (see Figure 8 - Piston Assembly, Figure 9 – Spring Orientation).
- 13.4 Screw base plug into body until fully seated, adjust the base cap to align the cutout on the cap with the locking screw. Install the base plug locking screw. – *6mm Allen Wrench*

### 14. Replace hex plug seal

- 14.1 Remove hex plug (20485) (see Figure 13). - *3/8in Socket & Torque Wrench*
- 14.2 Remove the old O-ring (3-906).
- 14.3 Lubricate the replacement O-ring with *Parker Super Lube or equivalent* and place onto hex plug.
- 14.4 Torque hex plug to 60 ft.lbf [81Nm]. – *3/8in Socket & Torque Wrench*

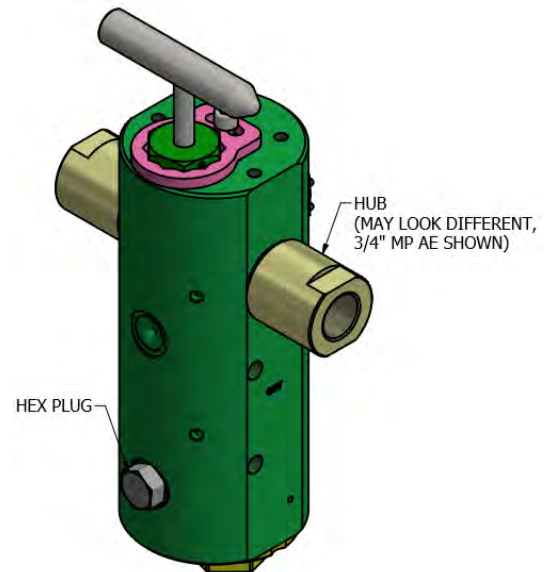
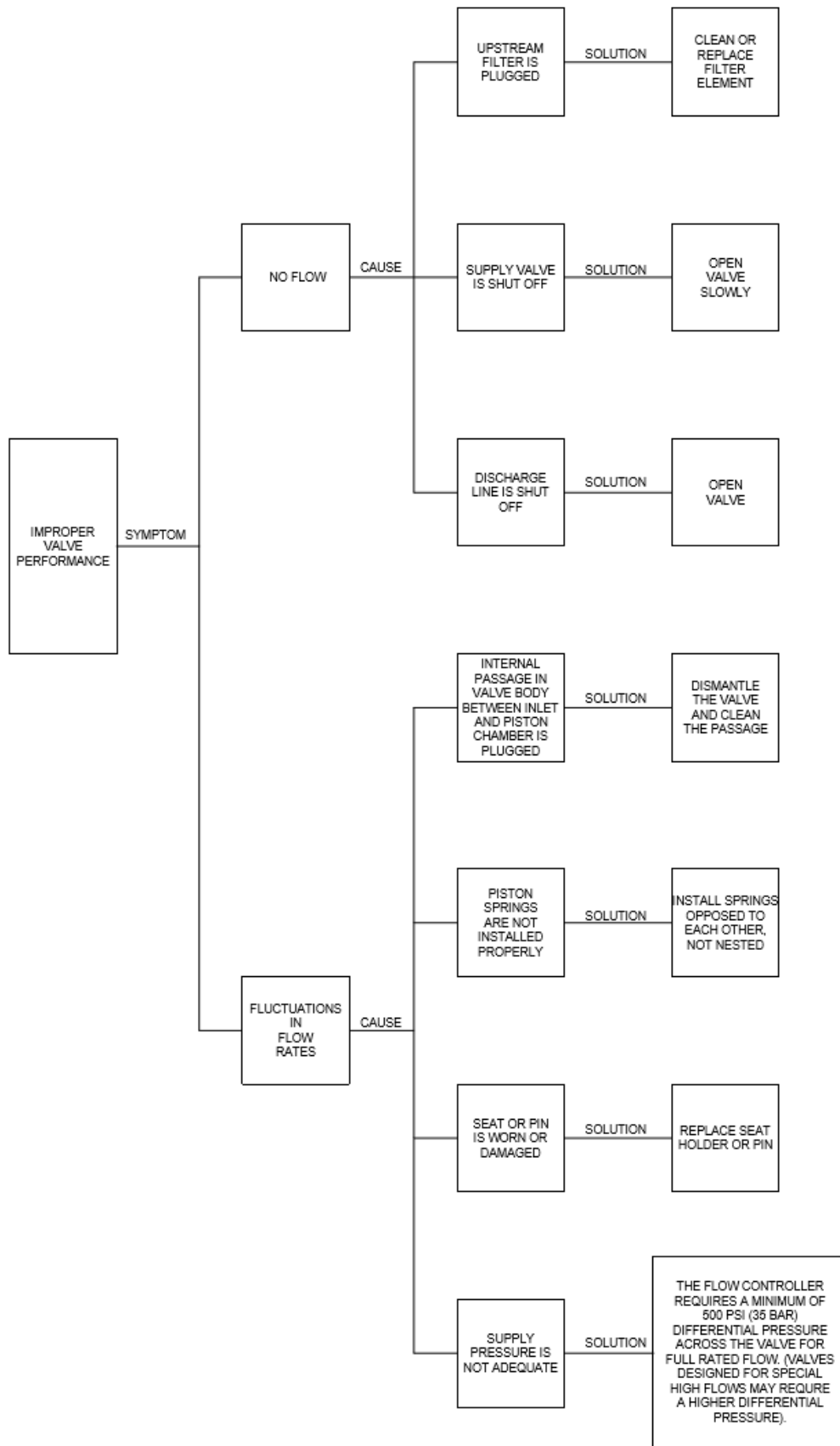

**Figure 13 - Hex and Hub**

### 15. Replace hub seals

- 15.1 Remove the hubs (see Figure 13). – *Torque Wrench & see Table 3 – Hub Wrenches*
- 15.2 Remove the old O-rings.
- 15.3 Lubricate the replacement O-rings with *Parker Super Lube or equivalent* and place onto hubs.
- 15.4 Screw the hubs into body.
- 15.5 Torque the hubs to 200 ft.lbf [271Nm]. – *Torque Wrench & see Table 3 – Hub Wrenches*

## TROUBLESHOOTING



**APPENDIX A – A TYPICAL CHEMICAL INJECTION SYSTEM**

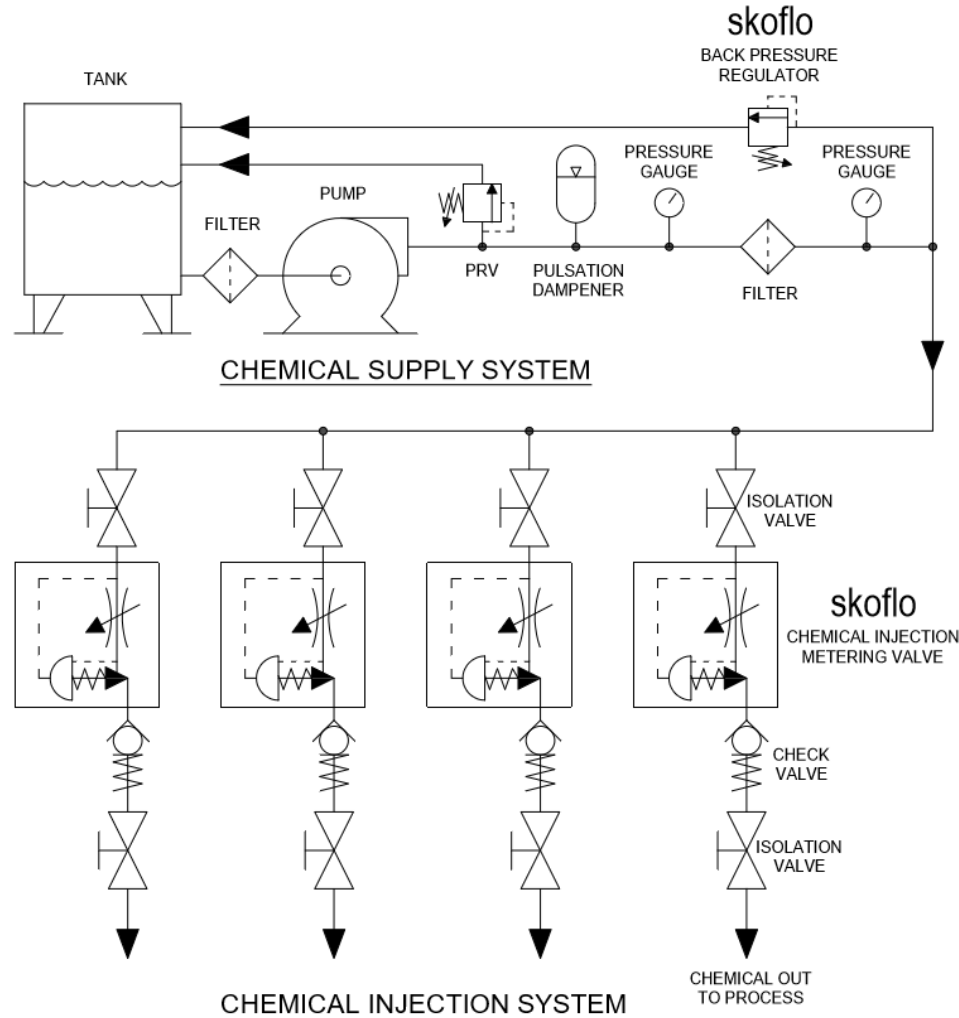

**NOTES**

Any number of injection points can be served by a single pump and header system. The only limitation is the flow capability of the pump.

Check valve shall be installed within 5 feet of the SkoFlo Valve.

APPENDIX B – SF10000NMFE GA AND BOM DRAWING

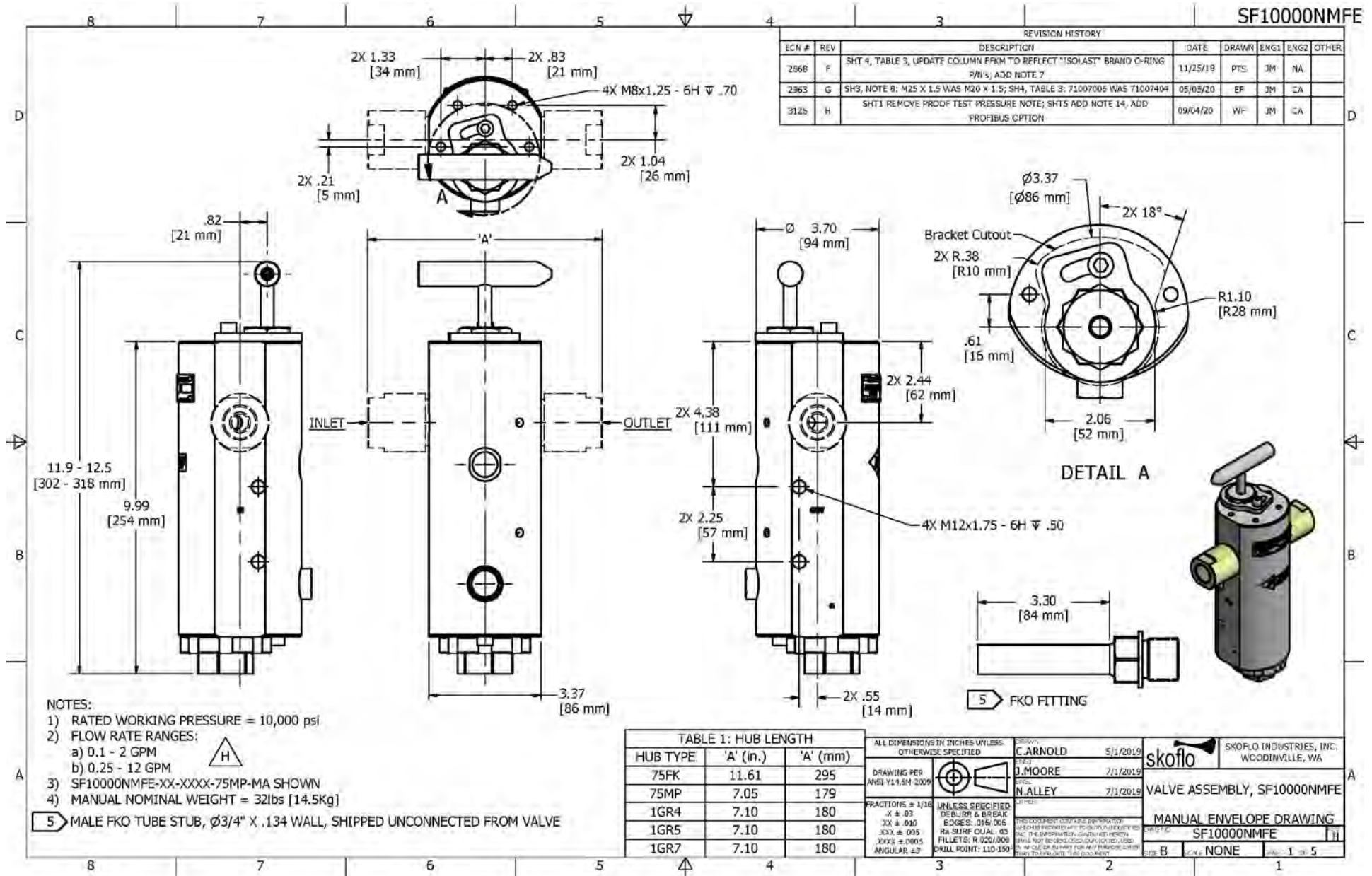



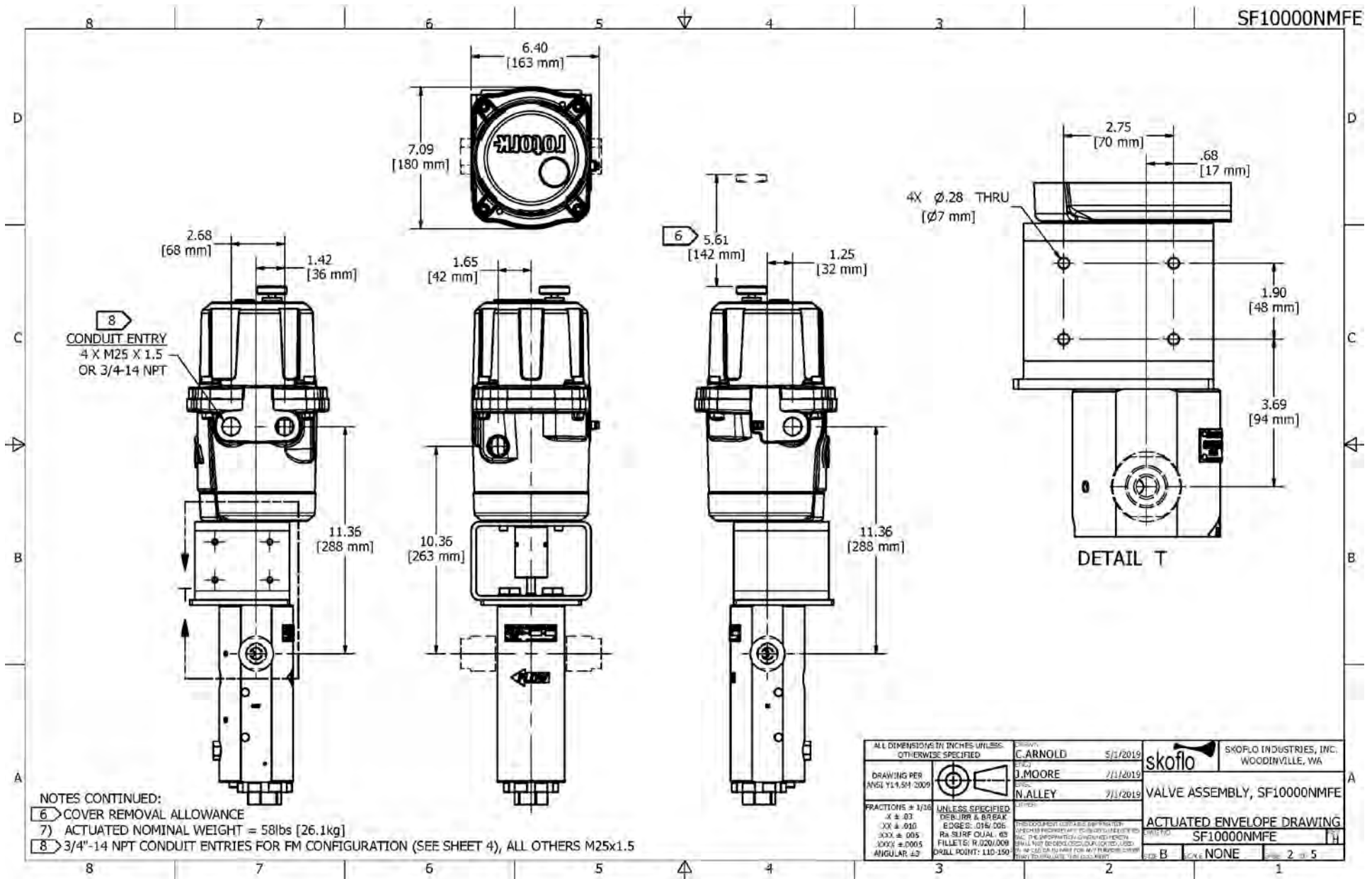

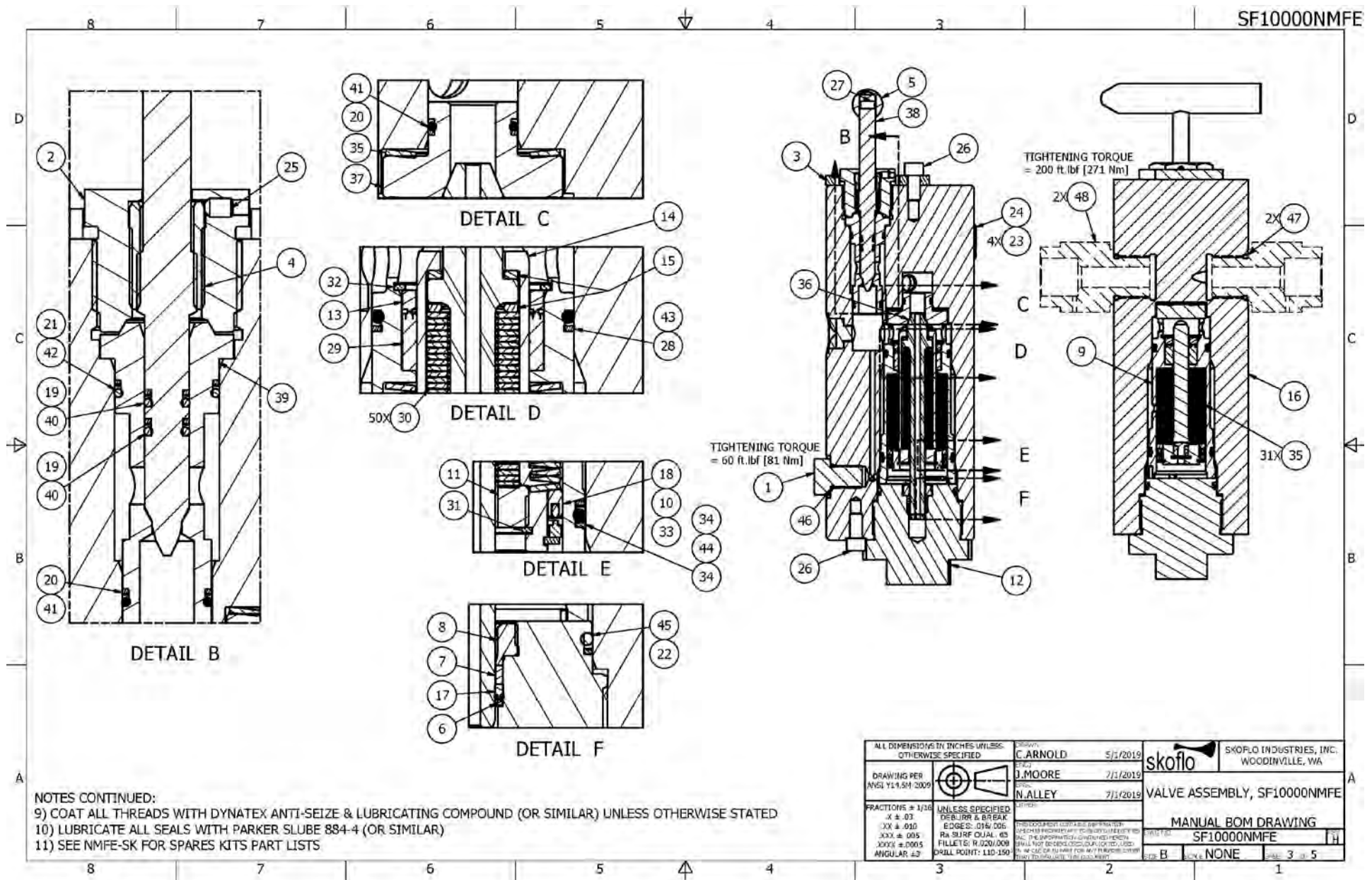



PARTS LIST					
ITEM	QTY	PART NUMBER	DESCRIPTION	PRESSURE CONTAINING	
1	1	20405	PLUG, HEX HEAD, 3/8 SAE	NITRONIC 50 HS	YES
2	1	20675	NUT, RETAINER, STEM, NMF	316 SS	YES
3	1	20677	PLATE, LOCK, NUT, RETAINER	316L SS	NO
4	1	20681	BUSHING, STEM, RFR-NF/NMFE	AL-NI-BR7, CG3000	NO
5	1	20693	HANDLE, NMF	316L SS	NO
6	1	26627	RETAINER, BU RING, Ø .49 OD, Ø .41 ID	316L SE	NO
7	1	26836	SL, CUP, BU RING, Ø .5 OD, Ø .375 ID	PEEK	NO
8	1	27353	RETAINER, SEAL, 3/4-20 UNF-2A	NITRONIC 50 HS	NO
9	1	27354	RETAINER, SEAT, LINER	NITRONIC 50 HS	NO
10	1	27355	RETAINER, SEAL, PISTON, OUTER, Ø1.480D, Ø1.28ID	NITRONIC 50 HS	NO
11	1	27356	RETAINER, SPRING, 15/16 - 16 UN-2A	NITRONIC 50 HS	NO
12	1	27357	CAP, PISTON, NMF, 2 1/4 - 12 UN-2A	NITRONIC 50 HS	YES
13	1	27358	RETAINER, SEAL, Ø1.1850D, Ø.95ID	NITRONIC 50 HS	NO
14	1	27474	PISTON, NMF, COATED	NITRONIC 50 HS, CERAMIC COATED	NO
15	2	27731	WASHER, THRUST, COATED, Ø.750D, Ø.SLID	NITRONIC 50 HS, COATED	NO
16	1	28864	WELDMENT, BODY, NMF, 5AE-12	SEE DWG	YES
17	1	71001862	SL, CUP, Ø.500 OD, Ø.375 ID	SEE DWG	YES
18	1	71001872	SL, CUP, Ø1.50 OD X Ø1.25 ID	SEE DWG	NO
19	2	71001924	SL, BU RING, 8-010	PEEK	NO
20	2	71001930	SL, BU RING, 8-016	PEEK	NO
21	1	71001932	SL, BU RING, 8-018	PEEK	NO
22	1	71001943	SL, BU RING, 8-133	PEEK	NO
23	4	71002116	U-DRIVE SCREW, RH, #2X1/4	302 SS	NO
24	1	71002142	NAMEPLATE, SF10000	316L SS	NO
25	1	71002661	STSC, CUP, M4-7 X 6, 316 SS	316 SS	NO
26	2	28722-002	SHCS, M8-1.25 X 16 LG	A4-80	NO
27	1	71002937	STSC, CUP, M8-1.25 X 10MM	316 SS	NO
28	1	71005770	SL, BU RING, 8-128	PEEK	NO
29	1	71005976	SL, CUP, Ø1.188 OD X Ø.935 ID	SEE DWG	NO
30	50	71005978	SPRING, WASHER, Ø.77 OD X Ø.42 ID, .05 TH	ALLOY X-750	NO
31	1	71005979	SNRG, INTERNAL, Ø .385 OD, Ø .937 ID	316 SS	NO
32	1	71005980	SNRG, INT, Ø1.316 OD, Ø1.25 ID, FHE-012	INCONEL X-750	NO
33	1	71005981	SNRG, EXTERNAL, Ø1.25 OD, Ø 1.188 ID	ALLOY X-750	NO
34	2	71005987	SL, BU RING, 8-131	PEEK	NO
35	82	71005990	SPRING, WASHER, Ø1.460 OD X Ø.950 ID, .050 THK	ALLOY X-750	NO
36	1	SEE TABLE 2	PIN, PUSHROD	CARBIDE-BC6N	NO
37	1	SEE TABLE 2	SEAT	CARBIDE-BC6N	NO
38	1	SEE TABLE 2	STEM, NMF	NITRONIC 60	YES
39	1	SEE TABLE 2	TRIM, NMF	NITRONIC 60	YES
40	2	SEE TABLE 3	SL, O-RING, 2-010	SEE TABLE 3	NO
41	2	SEE TABLE 3	SL, O-RING, 2-016	SEE TABLE 3	NO
42	1	SEE TABLE 3	SL, O-RING, 2-018	SEE TABLE 3	YES
43	1	SEE TABLE 3	SL, O-RING, 2-128	SEE TABLE 3	NO
44	1	SEE TABLE 3	SL, O-RING, 2-131	SEE TABLE 3	NO
45	1	SEE TABLE 3	SL, O-RING, 2-133	SEE TABLE 3	YES
46	1	SEE TABLE 3	SL, O-RING, 3-906	SEE TABLE 3	YES
47	2	SEE TABLE 3	SL, O-RING, 3-912	SEE TABLE 3	YES
48	2	SEE TABLE 4	ADAPTER, HUB	SEE TABLE 4	YES

#### MANUAL CONFIGURATION NUMBER GUIDE

SF10000NMF	-	XX	-	XXXX	-	XXXX	-	MA
		0.1 - 2 GPM		2		EPDM		75FK 3/4" FKG
		0.25 - 12 GPM		12		FFKM		75MP 3/4" MP AE
		FLOW RANGE		FLOW CODE		FKM		1GR4 GRAYLOC 1GR4
						HNBR		1GR5 GRAYLOC 1GR5
						SEAL MATERIAL		1GR7 GRAYLOC 1GR7
								HUB CODE HUB TYPE

#### TABLE 2: FLOW SELECTION

ITEM	0.1 - 2 GPM	0.25 - 12 GPM	DESCRIPTION
36	29055	29054	COATED PIN-PUSHROD
37	27711	27359	SEAT
38	27135	20674	STEM
39	27134	20617	TRIM

#### TABLE 3: SEAL SELECTION

ITEM	EPDM	FFKM	FKM	HNBR	DESCRIPTION
40	71001738	71007006	71001739	71004920	SL, O-RING, 2-010
41	71001758	71001762	71001759	71005309	SL, O-RING, 2-016
42	71001766	71007394	71001767	71005310	SL, O-RING, 2-018
43	71005279	71005380	71005997	71005998	SL, O-RING, 2-128
44	71005317	71006000	71004129	71006001	SL, O-RING, 2-131
45	71001803	71007399	71005667	71005311	SL, O-RING, 2-133
46	71001818	71007403	71002333	71005098	SL, O-RING, 3-906
47	71001827	71007001	71006491	71006492	SL, O-RING, 3-912

#### TABLE 4: HUB SELECTION

ITEM	75FK	75MP	1GR4	1GR5	1GR7
48	31037	28865	28890	28891	28892
MATERIAL	SUPER DUPLEX 2507	NITRONIC 50 HS	NITRONIC 50 HS	NITRONIC 50 HS	NITRONIC 50 HS

12 PRESSURE CONTAINING FFKM O-RINGS SHALL BE GRADE J9523

ALL DIMENSIONS IN INCHES UNLESS OTHERWISE SPECIFIED	Drawn: C. ARNOLD 5/1/2019		SKOFLU INDUSTRIES, INC. WOODINVILLE, WA
DRAWING PER ANSI Y14.5M-2009	Checked: J. MOORE 7/11/2019		VALVE ASSEMBLY, SF10000NMF
	Released: N. ALLEY 7/11/2019		
FRACTIONS = 1/16 X = .03 XX = .015 XXX = .005 .XXXX = .0005 ANGULAR = 1/2	UNLESS SPECIFIED: DEBURR & BREAK EDGES: 0.016 DOK RA SURF: 0.408 FILLETS: R.020/0.008 DRILL POINT: 110-150	THIS DOCUMENT IS THE PROPERTY OF SKOFLU INDUSTRIES, INC. IT IS TO BE USED ONLY FOR THE PROJECT AND NOT BE REPRODUCED, COPIED, OR DISTRIBUTED WITHOUT THE WRITTEN PERMISSION OF SKOFLU INDUSTRIES, INC.	MANUAL PARTS LIST SF10000NMF

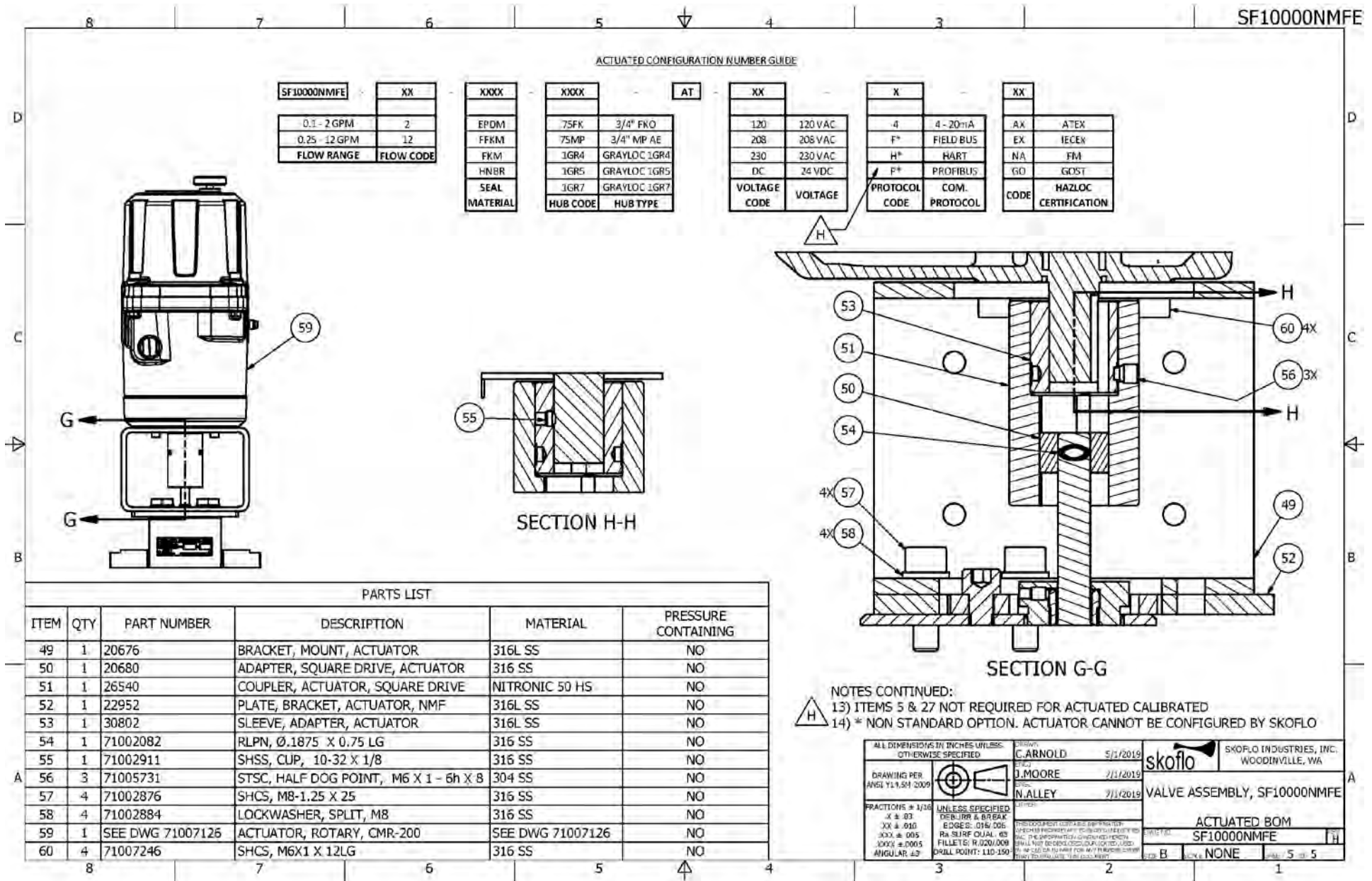



SkoFlo Industries  
14241 NE 200<sup>th</sup> Street  
Woodinville, WA 98072 USA  
Tel 1-425-485-7816  
Fax 1-425-368-1696

[www.SkoFlo.com](http://www.SkoFlo.com)